



Toll Free: (866) 5ATM-INC
Main Office: (248) 932-5400
24/7 Technical Support: (866) 638-5918
Fax: (248) 932-5404

Hyosung 1500 Manual

Table of Contents

1. Introduction	
1.1 About Mini Bank 1500	1-2
1.2 Features	1-2
1.3 What is in this Manual	1-3
2. Safety Precautions	
2.1 Overview	2-2
2.2 Description of Precaution Symbols	2-3
3. Hardware Specifications	
3.1 Dimension	3-2
3.2 Component Locations	3-3
3.3 LCD & Customer Keypad	3-4
3.4 Cash Dispenser Unit	3-5
3.5 Receipt Printer	3-6
3.6 Main Control Board	3-7
3.7 Operating Environment	3-8
3.8 Optional Devices	3-9
4. Installation	
4.1 Unpacking	4-2
4.2 Physical Installation	4-3
4.3 Hardware Installation	4-5
5. Operating Instructions	
5.1 Opening and Closing the Security Door	5-2
5.2 Opening and Closing the Front Panel	5-4
5.3 Replenishing the Cash Cassette	5-6
5.4 Emptying the Reject Bin	5-9
5.5 Loading the Receipt Paper	5-10
5.6 Additional Instructions (Option)	5-12

6. Operator Functions

6.1 Basic System Operation6-2
6.2 Settlement6-6
6.3 Journal6-14
6.4 Report6-26
6.5 Diagnostics6-35
6.6 Customer Setup6-46
6.7 System Setup6-60
6.8 Host Setup6-78
6.9 Transaction Setup6-106

7. Appendix

A. Receipt Paper Specifications7-2
B. Note Conditions (Acceptable/Unacceptable)7-3
C. Operating and Changing the Electronic Combination Lock7-6
D. Error Codes7-8
E. How to Clear NV-RAM7-11
F. Pictures of Mini Bank 15007-13

Chapter 1. Introduction

1. Introduction

1.1 About the Mini Bank 1500

The Mini Bank 1500 is designed to meet the everyday demands of immediate cash needs for individuals with a compact size to fit in virtually any place. This Automated Teller Machine (ATM) is connected to a network processor to verify accounts and any other inquiries through the insertion of a customer's card. The Mini Bank 1500 is easy to use, easy to service and is able to support customer's needs.

1.2 Features

H/W Features

- UL 291 Business Hour Service
- Mechanical combination lock
- Electronic combination lock (option)
- 320 × 240 Resolution of back-lit LCD / color display (option)
- Dial-up telephone line instead of expensive leased line
- 1,200/2,000 new notes capacity (USD)
- DIP type magnetic card reader / smart card reader (ISO 1,2,3 track)
- Automated receipt printer paper loading
- Thermal receipt printer for high speed printing with graphics
- Modular design for easy maintenance

Functional Features

- Electronic journal with up to 2,000 transactions, up/down loading supported
- Supports English, Spanish, French, Korean and Japanese
- Detailed average history report feature
- Quick setup feature
- Advertisement feature for store promotion
- Error code description for easy to service

1.3 What is in this manual

This Mini Bank 1500 Automated Teller Machine Manual contains all information needed for normal operational use.

This manual contains Unit Specifications, ATM Opening & Closing Procedures, Operator Functions, Customer Transactions, Error Recovery and etc.

Some of the information in this manual may differ according to the network processor to be connected.

Chapter 2. Safety Precautions

2. Safety Precautions

2.1 Overview

Common Safety Precaution



Safety Precautions outlined in this manual provide information on safe and proper handling of the product. Non-compliance of the safety precautions may result in injury or damage to the product. This precaution symbol with sample term tells you safety warnings in time of equipment handling.

2.2 Description of Precaution Symbols

Symbol	Description
	<p>Electrical Shock Warning</p> <ul style="list-style-type: none"> • Do not remove cover. Only a maintenance engineer should open the cover. • Do not touch. You may receive electric shock. • Make sure to turn off the power when servicing the equipment.
	<p>High Temperature Warning</p> <ul style="list-style-type: none"> • Do not touch the equipment when it is running. • The equipment can get extremely hot and may cause a burn. • Make sure to close the cover before running the equipment.
	<p>Use Caution when Moving</p> <ul style="list-style-type: none"> • The equipment is heavy. Make sure at least 2 people lift or move the equipment. • Do not attempt to move the equipment alone. You may be injured from dropping the heavy equipment.
	<p>Fire Hazard</p> <ul style="list-style-type: none"> • Place the equipment in an area away from any combustible materials. • The equipment may catch on fire from overheating or short circuit of the power supply unit.
	<p>Disassembly Warnings</p> <ul style="list-style-type: none"> • Do not disassemble or modify the equipment unless you are a certified engineer. • Contact the service center for maintenance, adjustments and repairs. • Improper disassembly may cause fire or electrical shock.
	<p>Collapse Precautions</p> <ul style="list-style-type: none"> • Do not place the equipment where the floor cannot sustain the weight of the equipment, or on slanted or unstable surface. • Equipment may fall and cause injury or damage.

Symbol	Description
	<p>Unplug the Equipment</p> <ul style="list-style-type: none">• Stop using the equipment immediately if it smokes, emits an unusual smell, makes abnormal sounds, or if liquids or other foreign materials enter the equipment.• If the above-mentioned abnormalities occur, immediately turn off the power, unplug the equipment and contact the service center.• If you ignore these symptoms, the equipment may catch on fire or cause electric shock.

Chapter 3. Hardware Specifications

3. Hardware Specifications

3.1 Dimensions

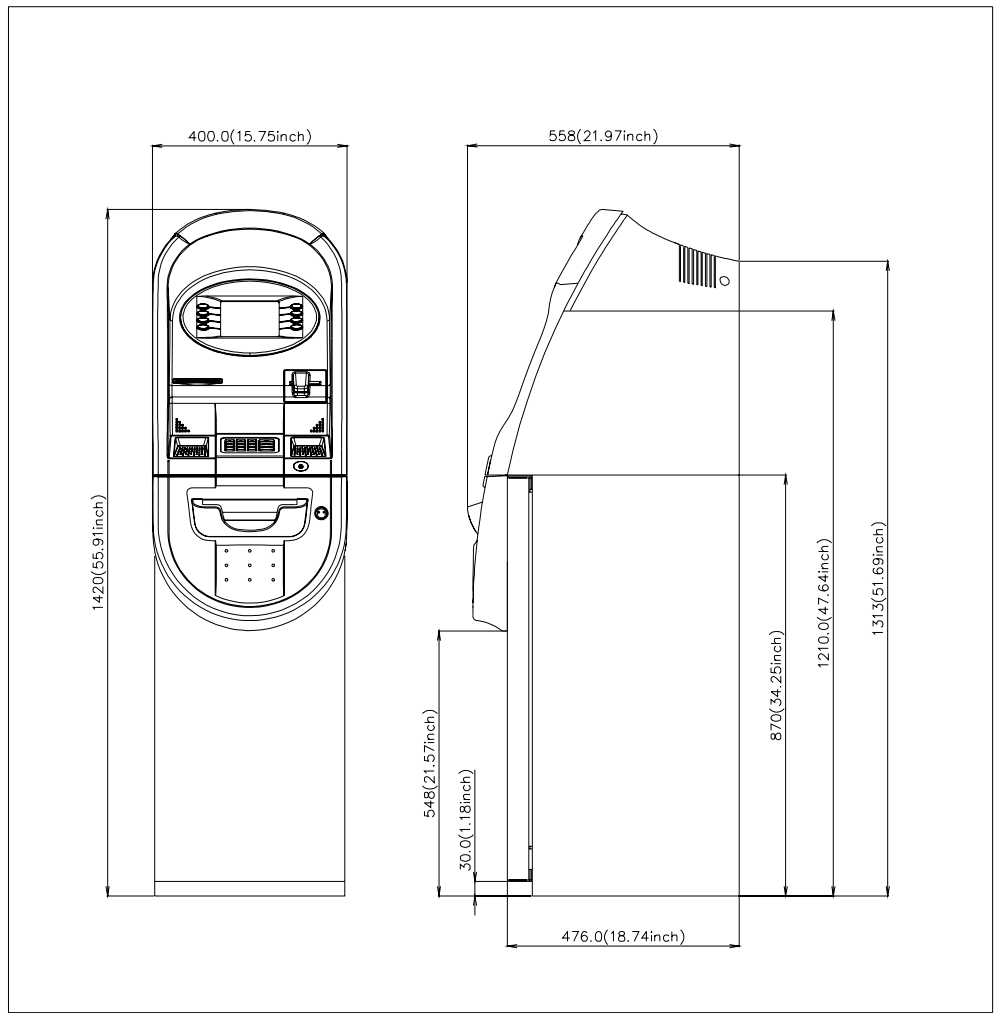

Weight : 306 lbs. (139 kg.)

Fig. 3-1 Mini Bank 1500 Dimension

3.2 Component Location

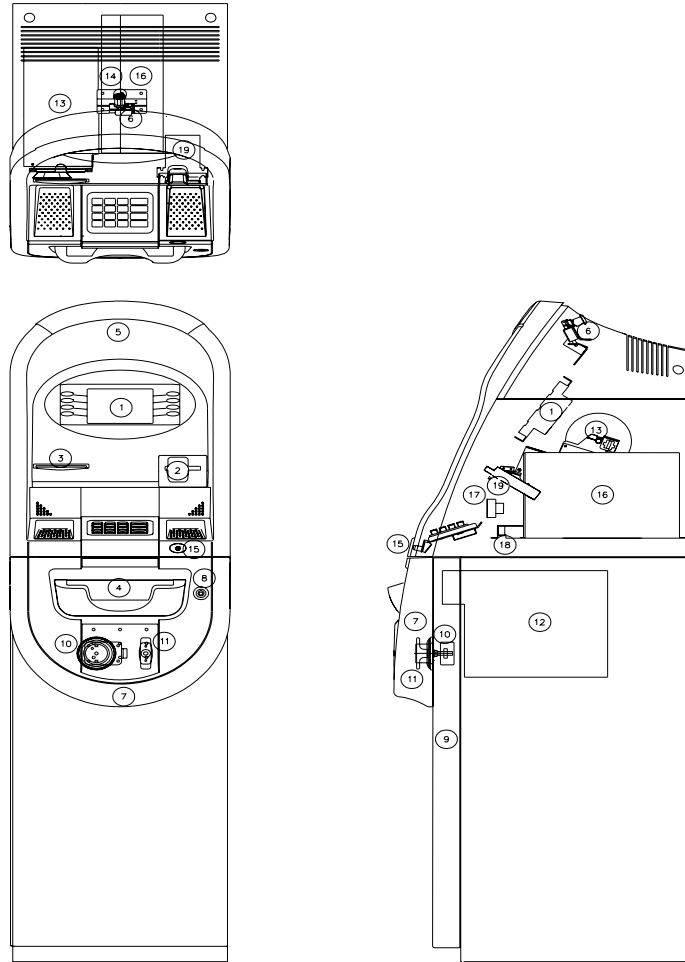

Fig. 3-2 Component Location

- | | |
|--------------------------|---------------------------------|
| 1. LCD & Customer Keypad | 11. Security Door Handle |
| 2. Card Reader Slot | 12. Cash Dispensing Unit |
| 3. Receipt Printer Slot | 13. Receipt Printer |
| 4. Cash Tray | 14. Main Control Board |
| 5. Front Panel | 15. Earphone Jack (ADA, Option) |
| 6. Front Panel Lock | 16. Power Supply |
| 7. Security Cover | 17. Speaker |
| 8. Security Cover Lock | 19. Card read |
| 9. Security Door | |
| 10. Combination Lock | |

3.3 LCD & Customer Keypad



Fig 3-3 LCD & Customer Keypad

LCD

- Screen Size : 6"
- Mono / Color(Optional)
- Resolution : 320 × 240
- Display Characters : 40 × 15 (Standard Character)

Keypad

- 10 Alphanumeric , ◀ , ▶ , CANCEL, CLEAR, ENTER, BLANK Keypads
- 8 Function Keys
- Each Keypads has integral raised Braille symbols

ADA Port (option)

- Voice assisted operation available through the headphone jack on the front bezel

3.4 Cash Dispenser Unit



Fig. 3-4 Cash Dispenser Unit

Cash Dispenser Unit

- Dispensing speed : 4 notes/second
- Capacity of 1,200 new notes (standard dispenser)
- Reject bin with capacity of 200 notes
- Low level cassette detection
- Double note detect module

3.5 Receipt Printer



Fig. 3.5 Receipt Printer

Receipt Printer

- Thermal line printer with cutter
- 36 characters/line
- Semi-Automatic roll paper setting
- Support graphics / Bar Code printing
- See Appendix A : RECEIPT PAPER SEPECIFICATIONS

3.6 Main Control Board



Fig. 3.6 Main Control Board

- Modem : 56kbps dial-up modem (standard)
- Electronic Journal : Max 2,000 transactions
- Battery back-up for set-up parameters
- Real Time Clock

3.7 Operating Environment

Power Requirements

115 Vac \pm 10%	3.0A	60Hz , 350 Watt
230 Vac \pm 10%	1.5A	50Hz , 350 Watt

Power Connections

The Mini Bank 1500 ATM must be connected to a dedicated power circuit. This circuit must consist of **LINE**, **NEUTRAL** and **GROUND** leads connected directly to the power circuit breaker panel. This circuit cannot be shared with any other equipment.

Phone Line Requirements

The Mini Bank 1500 ATM must be connected to a dedicated phone line. This line must be a direct dial “tone” or “pulse” line that is equipped with a standard telephone wall jack (RJ-11). This line cannot be shared with any other equipment at the location.

Temperature

- In storage : 32°F - 123°F (0°C ~ 49°C)
- While operating : 40°F - 95°F (5°C ~ 35°C)

Humidity

- In storage : 10% < RH < 90%, Non-Condensed
- While operating : 15% < RH < 85%, Non-Condensed

3.8 Optional Devices

A. Cash Dispenser

1. CDU-L Type

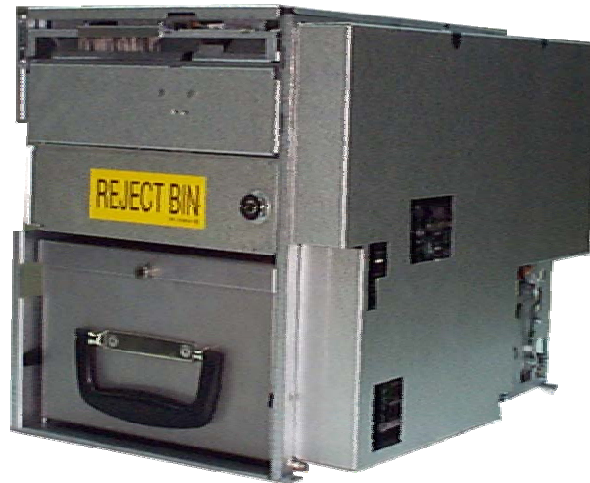

Fig. A-1 Cash Dispenser Unit (CDU-L Type)

Cash Dispenser Unit

- Dispensing Speed : 7 notes/second
- 1 Cash Cassette with capacity of 2,000 new notes(US Dollar)
- Reject Box with capacity of 200 notes
- Low Level Cassette Detection
- Double Pick Detect Module

2. CDU-M Type



Fig. A-2 Cash Dispenser Unit (CDU-M Type)

Cash Dispenser Unit

- Dispensing Speed : 7 notes/second
- 1 Cash Cassette with capacity of 2,000 new notes(US Dollar, Upto 3 cassette option)
- Reject Box with capacity of 200 notes
- Low Level Cassette Detection
- Double Pick Detect Module

Chapter 4. Installation

4. Installation

4.1 Unpacking

- 1) Unpack the machine on top of the pallette.
- 2) Cut the straps that are fastened around the box with a knife. (refer to Fig. 4.1.1)
(Be careful when cutting the straps.)
- 3) Use an appropriate tool to remove the nails from the pallette. (refer to Fig. 4.1.2)
- 4) Remove the lid, then box from the top. Do not discard the packaging materials until you have verified any shipping damage claim. Contact your distributor immediately if you see any shipping damage.
Store the box in a safe place to re-use or discard of appropriately.
- 5) Verify the contents carefully with the packing list to be sure all items listed are included. Notify your distributor of any shortages.
- 6) If only the pallette needs to be removed, lift the whole machine from the bottom and set it aside.

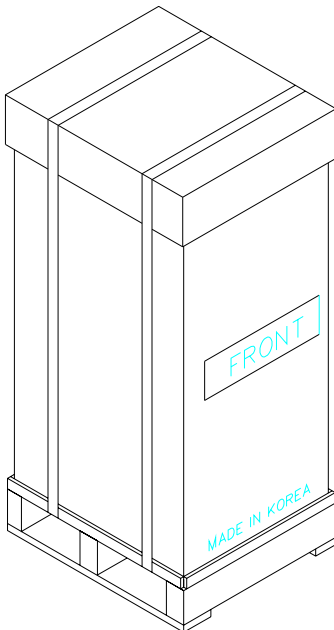

Fig. 4.1.1

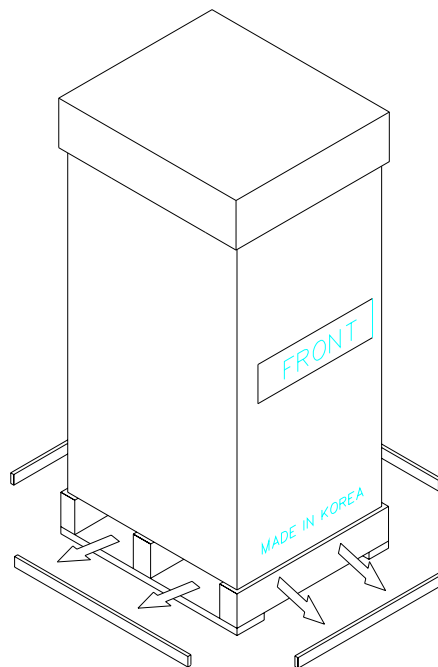

Fig. 4.1.2

4.2 Physical Installation

To install the Mini-Bank 1500 series ATM, perform the following steps.

- 1) Place the “Anchor bolts locate sheet” at the place where the machine is to be installed. (refer to Fig. 4.2.1)
- 2) Place the system on a flat surface, the system has a tendency to tip over if the surface is over 10 degrees. (refer to Fig 4.2.2) Be careful when opening the top or bottom of the machine s it will be off balance
- 3) Place the Anchor nuts into the ground according to the anchor bolts locate sheet. (4 places)
- 4) Place the Mini-Bank 1500 on top of the sheet.
- 5) Open the Security cover with the key provided.
- 6) Using the supplied combination (factory preset at 50-25-50) open the Security Door. This combination should be changed as soon as possible. Refer to Appendix B for instructions on changing the lock combination.
- 7) After the anchor nuts are in place according to the anchor holes on the bottom of the Mini Bank 1500, tighten the anchor bolts tightly. (refer to Fig. 4.2.3)

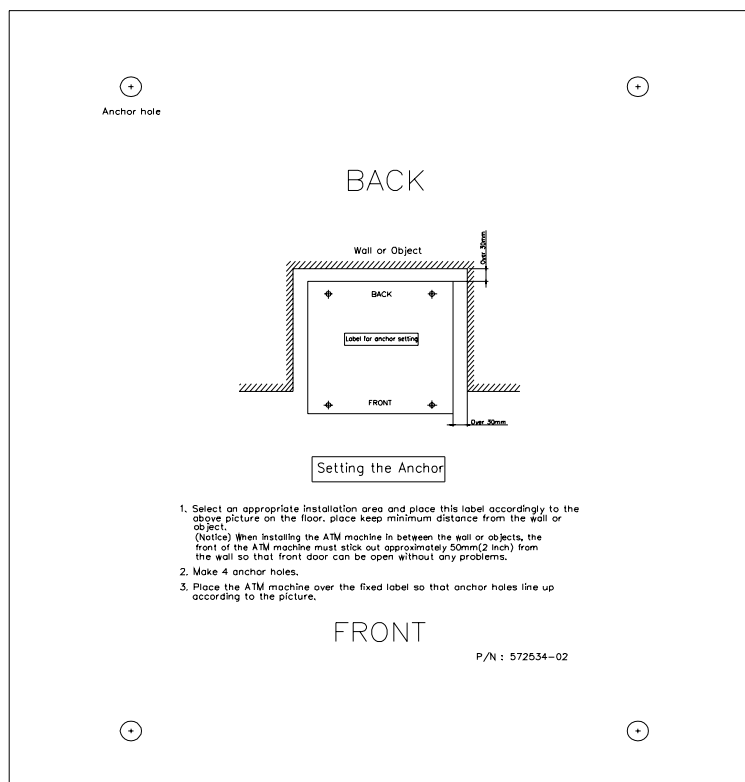

Fig. 4.2.1

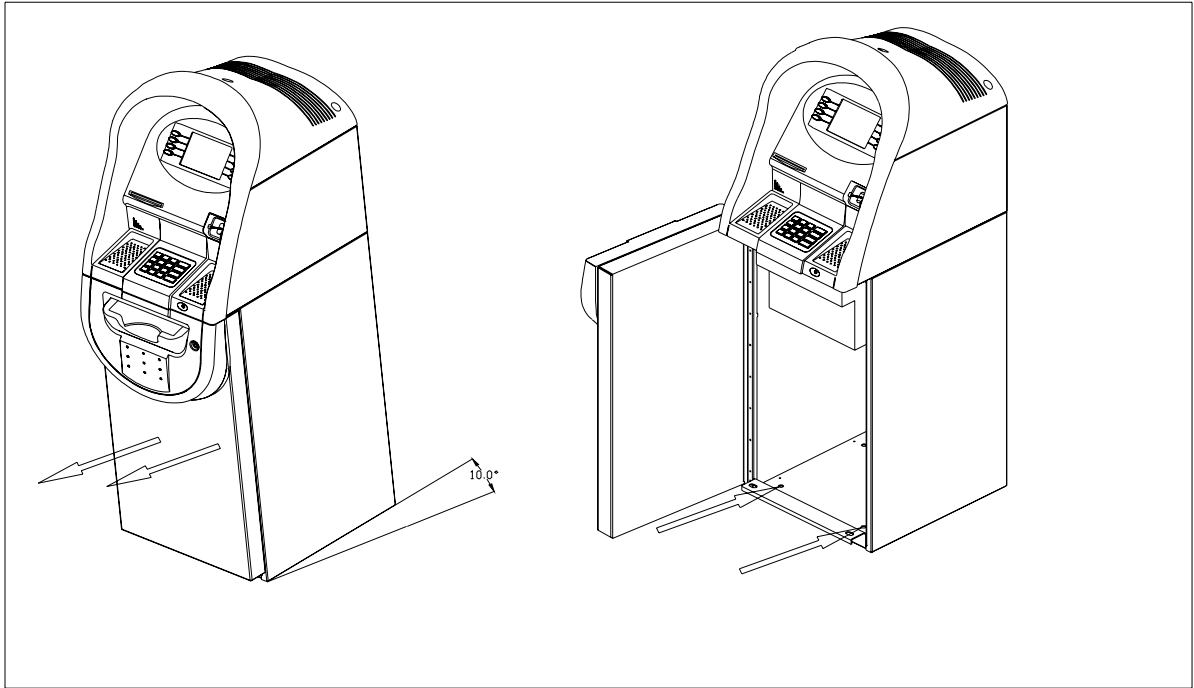

Fig. 4.2.2

Fig. 4.2.3

4.3 Hardware Installation

- 1) Verify the power voltage (110/220V) to be used and set the appropriate voltage on the power supply.
- 2) Verify that the telephone line to be used for the ATM is in proper working order. Hyosung recommends the use of shielded phone line in locations with close proximity to other appliances.
- 3) Open the security door and remove any shipping materials and note any warning or installation instructions.
- 4) Remove the screw, which is set to hold the Cash Dispensing Unit platform in place.
- 5) Remove the cash cassette from the box, fill the cassette with the appropriate amount of notes, and place it in the Cash Dispensing Unit carefully. Place the appropriate denomination label on the front of the cassette.
- 6) Before closing the vault, thoroughly test the combination lock by locking and unlocking the lock several times. It is much easier to diagnose potential lock problems before shutting the door
- 7) Open the top of the ATM. Place the receipt paper in the Receipt Printer. The paper prints only on one side (shiny side) always check the roll when you install paper. Place the roll so that the coated side (shiny side) will be facing up.
- 8) Connect the Power cable and telephone cable to the appropriate outlets on the wall. (verify once again if the power voltage is 110V or 220V)
- 9) Turn the power on and verify if all systems are operational. If any part of the system is not operational then an error code will be displayed. Verify with the Error Code and follow the appropriate steps. If the error is not corrected please contact your local distributor. Set all the system parameters. For more detailed information refer to Section 6 and Section 7.

Chapter 5. Operating Instructions

5. Operating Instructions

5.1 Opening and Closing the Security Door

Opening the Security Door



- 1) Turn the Security Cover key clockwise to open the Security Cover.



- 2) To unlock the Combination Lock



- 3) Turn the Security Door Handle counter-clockwise, then pull the Security Door to open.

Fig.5.1a Opening the Security Door

Closing the Security Door



- 1) With the Security Door Handle turned counter-clockwise, close the Security Door and turn the Security Door Handle clockwise until it is locked.



- 2) After close of security door, the door will automatically lock in 5~6 secs.



- 3) With the Security Cover key turned clockwise, close the Security Cover and turn the Security Cover key counter-clockwise until it is locked. Remove the key when it is locked.

Fig.5.1b Closing the Security Door

5.2 Opening and Closing the Front Panel

Opening the Front Panel



- 1) Insert the Front Panel key and turn it clockwise.



- 2) With the Front Panel key turned, pull the Front Panel outward.

Fig. 5.2a Opening the Front Panel

Closing the Front Panel



- 1) Push the Front Panel slowly until it is locked back in place.



- 2) Turn the Front Panel key counter-clockwise until the Front Panel key is able to be taken off.

Fig. 5.2b Closing the Front Panel

5.3 Replenishing the Cash Cassette



- 1) Open the Security Door.
(Please see 5-1 Opening and Closing the Security Door)



- 2) Push the cassette lock on the left side of cassette handle with finger in order to pull out cash cassette.



- 3) With one hand holding the cash cassette handle and the other hand supporting the cash cassette from the bottom, pull it out carefully.



- 4) Pull the cash plate back until it is locked against the cash plate latch.

Cash Plate

Cash Plate Latch

Fig. 5.3a Replenishing the Cash Cassette



- 5) Replenish the cash cassette.
(Refer to note below.)

Fig. 5.3a Replenishing the Cash Cassette

NOTE :

1. Fan the notes so that the notes do not stick together.
2. Remove all notes with holes or notes that are torn.
3. Unfold the folded notes.
4. Place the notes correctly.
Refer to Fig. 3.3b.

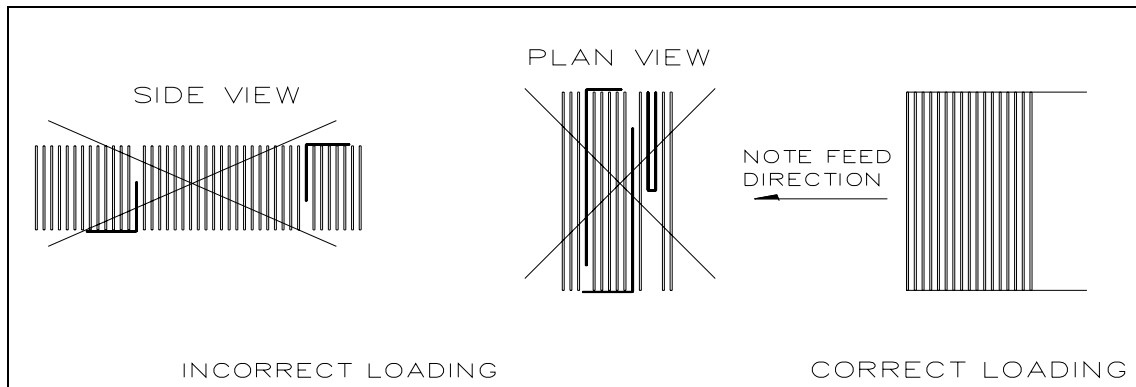

Fig. 5.3b Correct Loading of Cash



- 6) After replenishing the cash cassette, release the cash plate latch and allow the cash plate gradually take up its position behind the notes.



- 7) With one hand holding the cash cassette handle and the other hand supporting the cash cassette from the bottom, place the cash cassette carefully on the set guide of the Cash Dispensing Unit and push it in until it is locked in place.



- 8) Close the Security Door.
(See 5.1 Opening and Closing the Security Door)

Fig. 5.3a Replenishing the Cash Cassette

5.4 Emptying the Reject Bin



1) Open the reject bin cover.



2) Remove the notes in the reject bin.



3) Close the reject bin cover.

Fig. 5.4 Emptying the Reject Bin

5.5 Loading the Receipt Paper



- 1) Open the Front Panel.
(See 5-2 Opening and Closing the Front Panel)



- 2) When there is some receipt roll paper left, push down the head up lever and pull out the end of paper.

Head Up Lever

Fig. 5.5a Loading the Receipt Paper

- 3) Prepare the new paper roll. Refer to note below.

NOTE :

1. Make sure the roll is in it's proper roll form. (A deformed roll may cause jamming problems)
2. When replacing the new roll, make sure the end of the roll paper is clean cut. (See Fig. 5.5b)

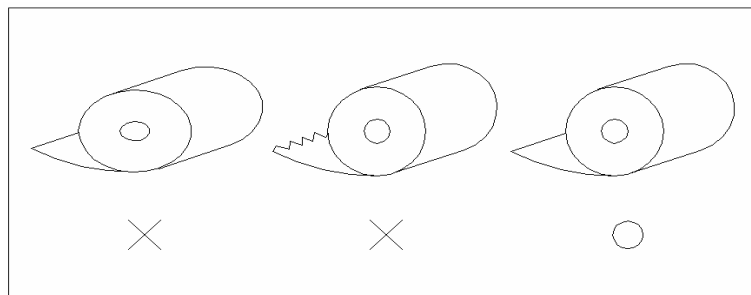

Fig. 5.5b Correct Shape of Roll Paper



- 4) Insert the Receipt Paper Rod in the middle of the Receipt Roll and set the Roll on the Roll deck. Then place the end of the paper into the setting guide.



- 5) When the paper is properly in place the receipt printer will automatically load the paper and will cut out one receipt.

NOTE : If there is any jammed paper left over, the receipt printer will not load the paper.



- 6) Remove the receipt paper and close the Front Panel. (See 5.3 Opening/Closing the Front Panel)

Fig 5.5a Loading the Receipt Paper

5.6 Additional Instructions (Option)

A. Electronic Combination Lock

Opening the Security Door



- 1) Turn the Security Cover key clockwise to open the Security Cover.



- 2) To unlock the Electronic Lock, refer to the Appendix B: Operating and Changing the Electronic Combination Lock.



- 3) Turn the Security Door Handle counter-clockwise, then pull the Security Door to open.

Fig.A-1 Opening the Security Door

Closing the Security Door



- 1) With the Security Door Handle turned counter-clockwise, close the Security Door and turn the Security Door Handle clockwise until it is locked. After close of security door, the door will automatically lock in 5~6 seconds



- 2) With the Security Cover key turned clockwise, close the Security Cover and turn the Security Cover key counter-clockwise until it is locked. Remove the key when it is locked.

Fig.A-2 Closing the Security Door

B. Replenishing the Cash Cassette



1) Open the Security Door.



2) With one hand holding the cash cassette handle and the other hand supporting the cash cassette from the bottom, pull it out carefully.



3) Place the cash cassette on a flat level platform and turn the cassette key clockwise to unlock the cash cassette cover.

Then lift the cash cassette cover.

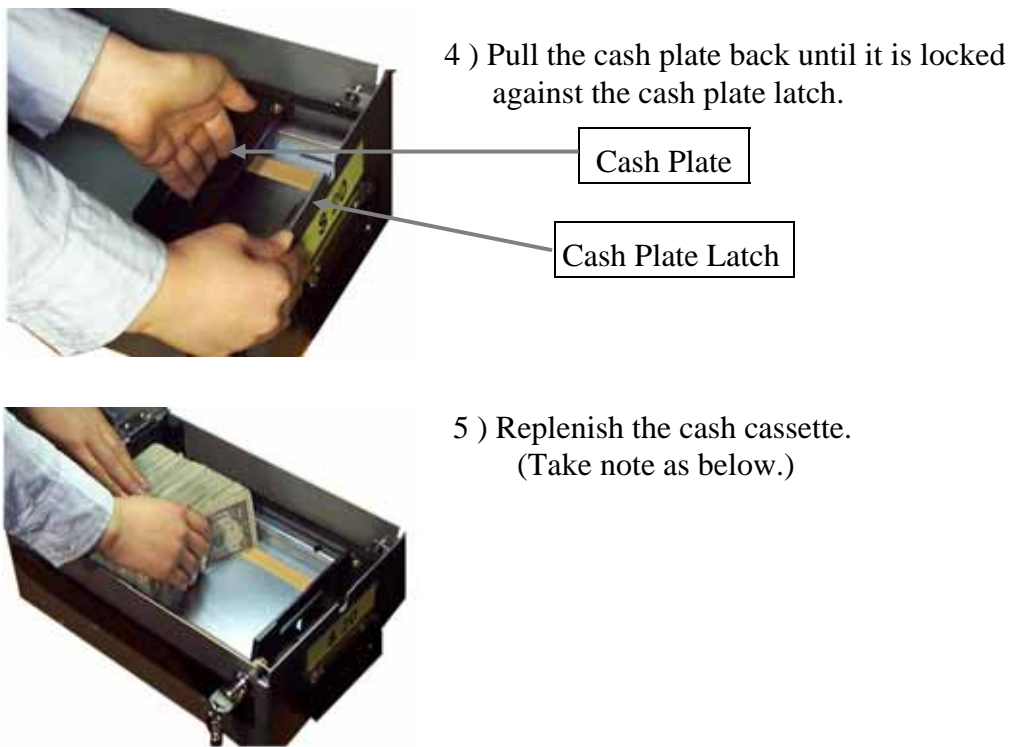

Fig. B-1 Replenishing the Cash Cassette

NOTE :

1. Fan the notes so that the notes do not stick together.
2. Remove all notes with holes or notes that are torn.
3. Unfold the folded notes.
4. Place the notes correctly.
Refer to Fig. 3.3b.

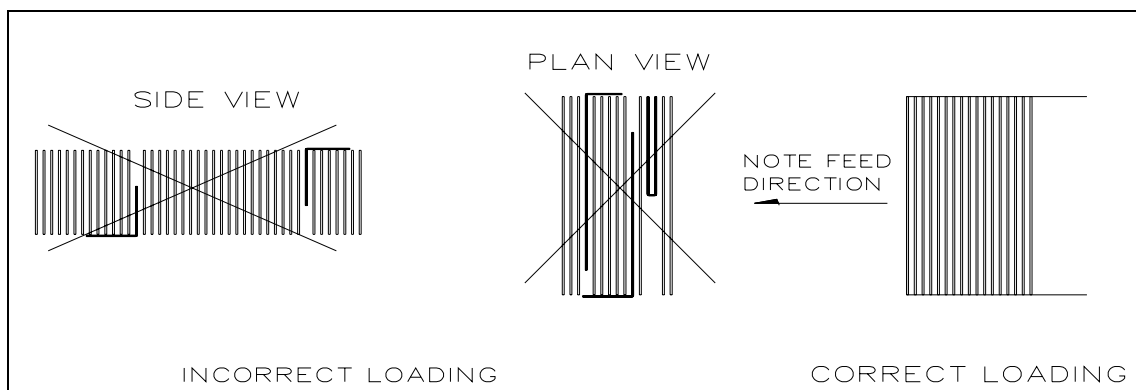

Fig. B-2 Correct Loading of Cash



- 6) After replenishing the cash cassette, release the cash plate latch and allow the cash plate to gradually take up its position behind the notes.



- 7) Close the cash cassette cover and turn the cassette key counter-clockwise until it is locked. Remove the key when it is locked.

NOTE :

If the cash plate is not released, the cassette cover will not close.



- 8) With one hand holding the cash cassette handle and the other hand supporting the cash cassette from the bottom, place the cash cassette carefully on the set guide of the Cash Dispensing Unit and push it in until it is locked in place.



- 9) Close the Security Door.

Fig. B-3 Replenishing the Cash Cassette

Chapter 6. Operator Functions

6. Operator Functions

6.1 Basic System Operation

6.1.1 Accessing the Operator Function Menu

6.1.1.1 General Method



- a. Turn on the Mini Bank 1500. The system will automatically be initialized and run the status check once when the Mini Bank 1500 is turned on. The system will attempt to connect to the host.

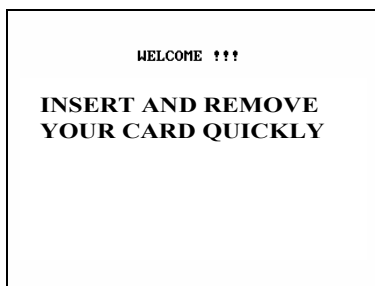

- b. If the host connection is established, the display will show "IN SERVICE" screen. Press the CANCEL, CLEAR, ENTER key simultaneously and then press 1, 2, 3 keys in order.



- c. Enter the Operator Password and press ENTER. If the wrong password is entered, the screen will be back to "ENTER PASSWORD" screen. The factory default Operator Password is "375876".

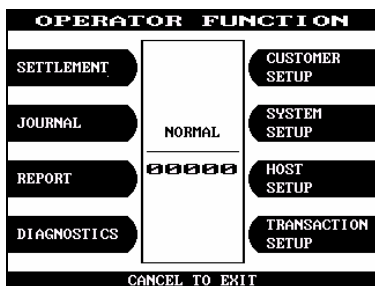

- d. If the correct password is entered, the OPERATOR FUNCTION menu will be displayed.

Fig. 6.1.1.1 General Method

6.1.1.2 When an Error Occurs

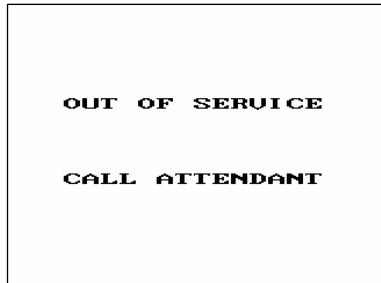

- a. When an error occurs, please press CANCEL, CLEAR, ENTER simultaneously and then press 1, 2, 3 in order.

Note: If the machine goes out of service, the error code will not always appear on the screen. If you do not see an error code, enter operator function and go to reports. Look in the error summary for error codes



- b. "ENTER PASSWORD" will be displayed and enter the Operator Password.

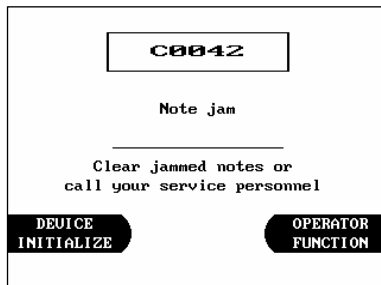

- c. When the screen is in current display, press the OPERATOR FUNCTION key to access the OPERATOR FUNCTION.

Fig. 6.1.1.2 When an Error Occurs

6.1.2 How to Use Keypad

This section will explain the basic operation of the Keypad.

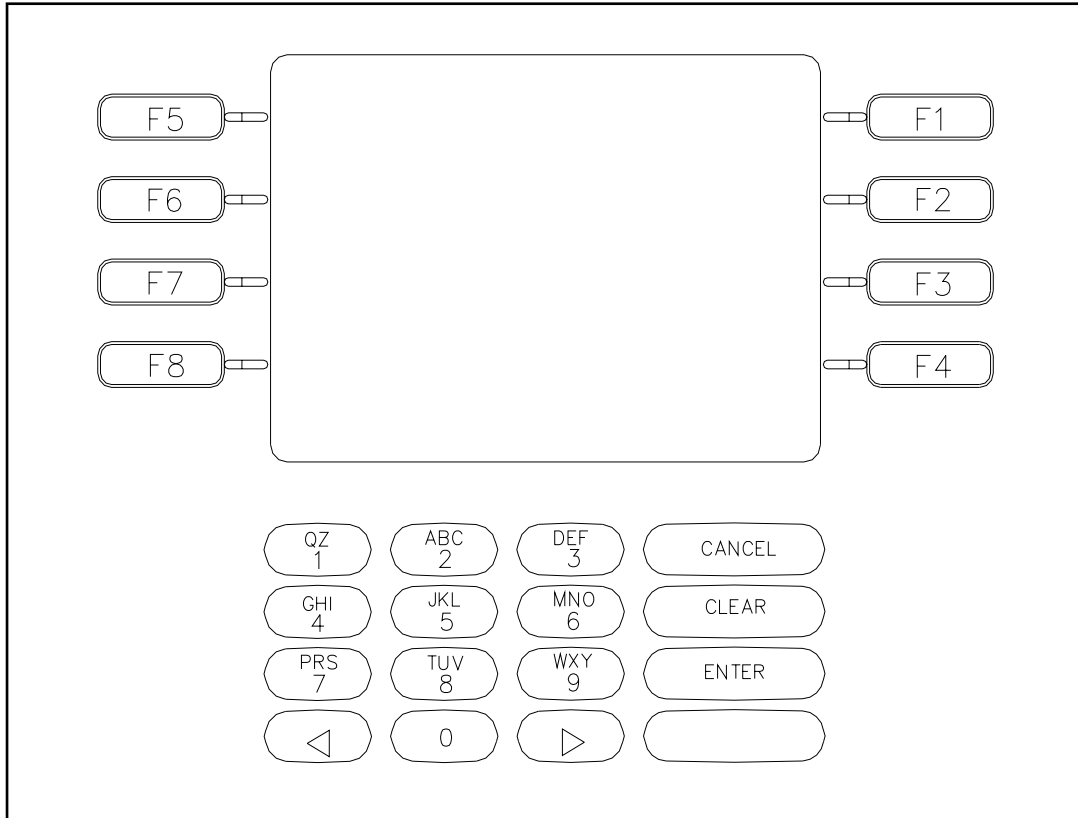

Fig. 6.1.2a Keypad

Shift Status				0	1	2	3	4	5	6	7	8	9
F5	Alpha	F6	Upper	+ - =	Space Q Z	A B C	D E F	G H I	J K L	M N O	P R S	T U V	W X Y
			Lower	+ - =	Space q z	a b c	D e f	G H I	j k l	m n o	p r s	t u v	w x y
	Numeric		Don't care	0 ()	1 []	2 { }	3 < >	4 , .	5 ! \$	6 ' "	7 % *	8 : ;	9 ? /
	Table		Don't care	The character on the current cursor position on the screen will be selected.									

Fig. 6.1.2b Keypad Character Table

How to Enter the Character

- a. The Keypad Character Table of Fig. 6.1.2b will appear on the bottom of the screen in all keypad input screens.
- b. F5 key gives the option for Alpha or Numeric, Table mode. Default is Alpha.
- c. F6 key gives the option for Upper or Lowercase characters. It is valid only in the Alpha mode. Default is Uppercase.
- d. The input of characters is limited to the space provided.
- e. Keys are in toggle fashion such as, when key “1” is pressed once it is “SPACE”, pressed twice it is “Q”, pressed third time it is “Z” when in the Alpha mode. When the desired character is selected, press ENTER.
- f. ◀, ▶ keys move the cursor position in the Alpha or Numeric mode. In the Table mode ◀, ▶ keys are used to select the character.
- g. F1 key is used to clear the whole screen and returns the cursor to its initial position.
- h. F2 key is used to clear the current line.
- i. F3 key is used to ignore the changes and to exit.
- j. F7 key is used to save the current changes and to exit.

6.2 Settlement

The Settlement Function of the Operator Function includes the following :

DAY TOTAL
CASSETTE TOTAL
SUBTOTAL (TRIAL) DAY TOTAL
SUBTOTAL (TRIAL) CASSETTE TOTAL
ADD CASSETTE #1

6.2.1 Day total

Accessing the DAY TOTAL

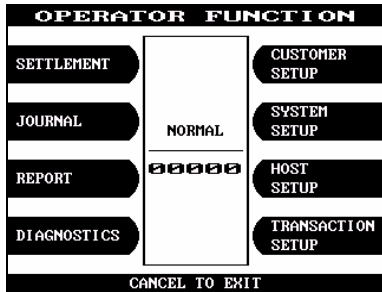

Select 'SETTLEMENT' in the 'OPERATOR FUNCTION' menu.

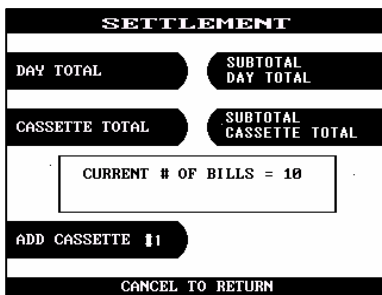

Select 'DAY TOTAL' in the SETTLEMENT menu.

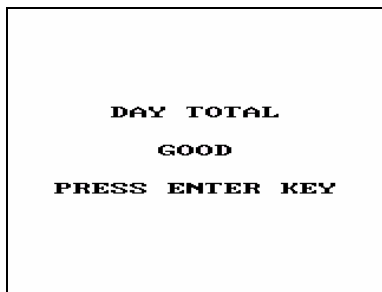

After the information is downloaded from the processor, the Day Total information will be printed from the Receipt Printer. If the GOOD message appears, press "ENTER".

Fig. 6.2.1 DAY TOTAL

Function Description

The DAY TOTAL includes all information of the ATM terminal totals and the host totals. If the host can not be connected, an "ERROR" message will be displayed and only the ATM terminal totals will be printed without verification with the host. All information will be deleted after the use of this function.

6.2.2 Cassette total

Accessing the CASSETTE TOTAL

Select 'SETTLEMENT' in the 'OPERATOR FUNCTION' menu.

Select 'CASSETTE TOTAL' in the SETTLEMENT menu.

The Cassette Total information will be printed from the Receipt Printer. If the GOOD message appears, press "ENTER".

Fig. 6.2.2 CASSETTE TOTAL

```

      CASSETTE TOTAL
=====
Start:  23/09/2003,  12:35:49
Today:  23/09/2003,  16:13:31
Terminal # ; 11111111
Loaded   ; 200
Dispensed ; 190
Rejected ; 0 (1 or more)
Test     ; 0.

-----
Remaining ; 10
Value of each note = £ 10

```

Fig. 6.2.2 A sample print out of CASSETTE TOTAL

Function Description

The CASSETTE TOTAL includes the total loaded number of bills in the cassette, the normal dispensed amount, the number of rejected notes, the test dispensed amount and the number of remaining notes, etc. since the last CASSETTE TOTAL was operated. This will be printed from the Receipt Printer. All information will be deleted after the use of this function.

6.2.3 Sub total (Trial) day total

Accessing the SUBTOTAL(TRIAL) DAY TOTAL

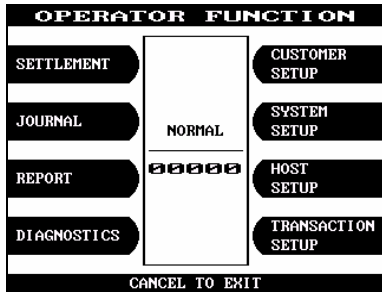

Select 'SETTLEMENT' in the 'OPERATOR FUNCTION' menu.

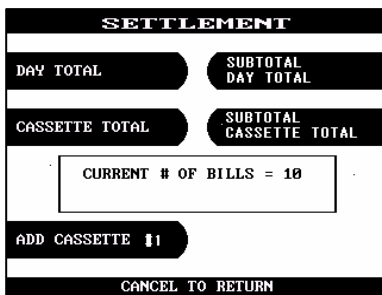

Select 'SUBTOTAL(TRIAL) DAY TOTAL' in the SETTLEMENT menu.

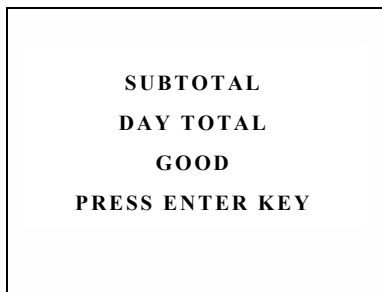

After the information is downloaded from the processor, the Subtotal Day Total information will be printed from the Receipt Printer. If the GOOD message appears, press "ENTER".

Fig. 6.2.3 SUBTOTAL DAY TOTAL

Function Description

The SUBTOTAL(TRIAL) DAY TOTAL function is used anytime to confirm the totals since the last DAY TOTAL. It does the same function as the DAY TOTAL, except the day total information is not cleared.

6.2.4 Sub total(Trial) cassette total

Accessing the SUBTOTAL(TRIAL) CASSETTE TOTAL

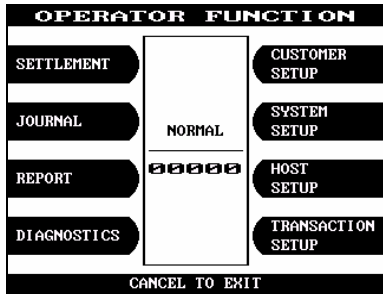

Select 'SETTLEMENT' in the 'OPERATOR FUNCTION' menu.

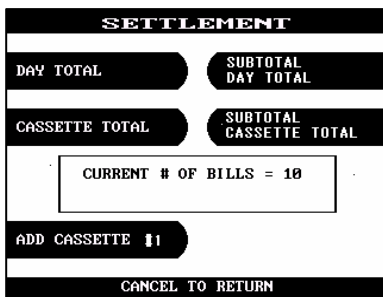

.Select 'SUBTOTAL(TRIAL) CASSETTE TOTAL' in the SETTLEMENT menu

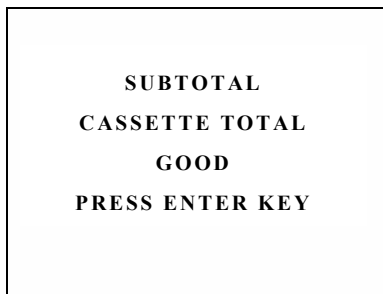

The Subtotal Cassette Total information will be printed from the Receipt Printer. If the GOOD message appears, press "ENTER".

Fig. 6.2.4 SUBTOTAL CASSETTE TOTAL

```
      TRIAL CASSETTE TOTAL
=====
Start:  23/09/2003,  16:13:31
Today:  23/09/2003,  16:17:44
Terminal # : 11111111
Loaded   : 200
Dispensed : 190
Rejected : 0 (1 or more)
Test     : 0

-----
Remaining : 10
Value of each note = £ 10
```

Fig. 6.2.4 A sample print out of SUBTOTAL CASSETTE TOTAL

Function Description

The SUBTOTAL(TRIAL) CASSETTE TOTAL function is used to check the amount dispensed from the cassette since the last CASSETTE TOTAL was operated. It does the same function as the CASSETTE TOTAL, except the cassette total information is not cleared.

6.2.5 Add d cassette #1

Accessing the ADD CASSETTE #1

The screenshot shows a terminal window titled "SETTLEMENT". At the top, there are two buttons: "DAY TOTAL" and "SUBTOTAL DAY TOTAL". Below these are two more buttons: "CASSETTE TOTAL" and "SUBTOTAL CASSETTE TOTAL". In the center, a text box displays "CURRENT # OF BILLS = 10". At the bottom, there are two buttons: "ADD CASSETTE #1" and "CANCEL TO RETURN".

Select 'ADD CASSETTE' in the SETTLEMENT menu.

The screenshot shows the same terminal window as above, but the text box now displays "CURRENT # OF BILLS = 100". All other elements, including the buttons, remain the same.

Set the number of bills loaded in the cassette.

NOTE : Enter the number of bills, NOT the amount of cash.

Fig. 6.2.5 ADD CASSETTE

Function Description

The operator must set the additional number of bills being loaded into the cash cassette at all times. After the use of CASSETTE TOTAL, the current number of bills will be reset to "0".

6.3 Jo urnal

The Journal Function of the Operator Function includes the following:

PRINT JOURNAL
LAST X PRINT
VIEW JOURNAL
CLEAR JOURNAL
CLEAR TRANSACTION SEQUENCE NUMBER
JOURNAL DOWNLOAD

6.3.1 Print journal

Accessing the PRINT JOURNAL

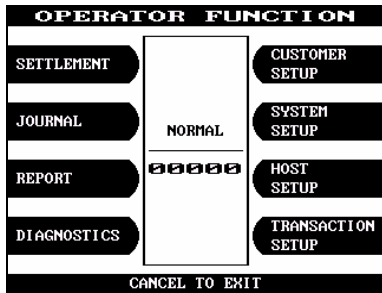

Select 'JOURNAL' in the OPERATOR FUNCTION menu.

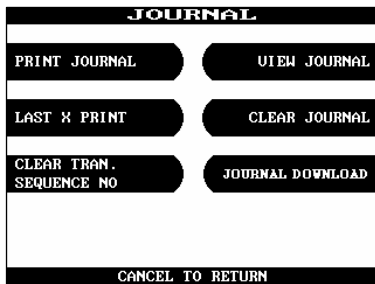

Select 'PRINT JOURNAL' in the JOURNAL menu.

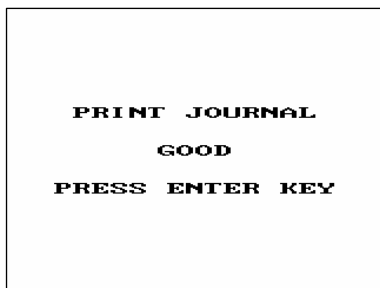

Wait while the Journal data is being printed.

If the GOOD message appears, press "ENTER".

Fig. 6.3.1 PRINT JOURNAL

```

-----
<00128 24/07/2003 PM 04:55:58
* ** NORMAL TRANSACTION ***

*** WITHDRAWAL ***
SEQUENCE NO : 0002
ACCOUNT FROM : CHECKING
CARD DATA : 211021310909
HOST DATE : 24/07/2003
HOST TIME : 16:56:03
AVAILABLE BAL : £ 3456.08
RETRIEVAL NO : 000010394
ALD T NO : 03098
NET ID : 5 6
BUSINESS DATE : 24/07/2003
SURCHARGE : £ 1.25
REQUESTED : £ 40.00
DISPENSED : £ 40.00
BALANCE : £ 45890.00
PROCCOUNT : 7

```

Fig. 6.3.1 A sample print out of PRINT JOURNAL

Function Description

The PRINT JOURNAL function is used to automatically print out any journal entries collected since the last time this command was operated.

6.3.2 Last X print

Accessing the LAST X PRINT(PRINT)

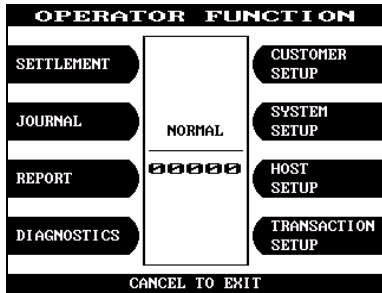

Select 'JOURNAL' in the OPERATOR FUNCTION menu.

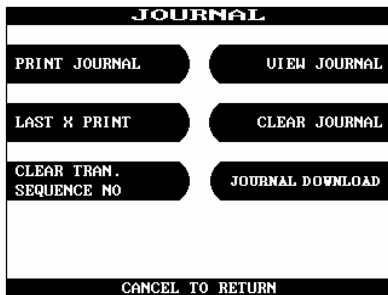

Select 'LAST X PRINT' in the JOURNAL menu.

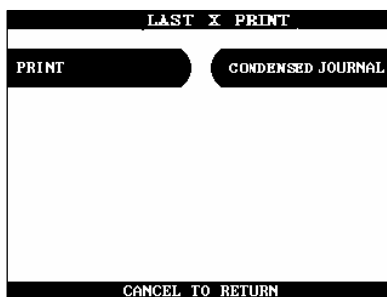

Select 'PRINT' in the LAST X PRINT menu.

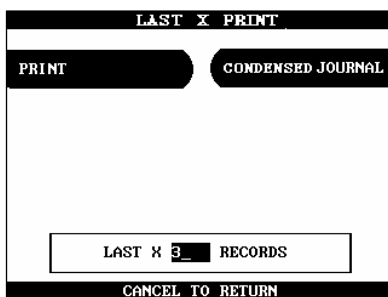

Enter the number of records to be printed. Wait while the Journal data is being printed.

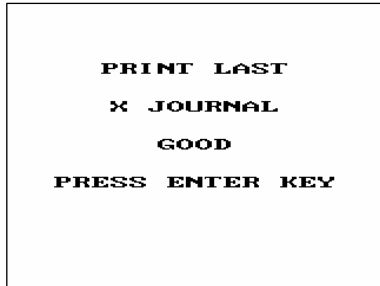

```
PRINT LAST
X JOURNAL
GOOD
PRESS ENTER KEY
```

If the GOOD message appears, press "ENTER".

Fig. 6.3.2 LAST X PRINT(PRINT)

Function Description

The LAST X PRINT(PRINT) function is used to reprint records for which the paper trail has been lost or destroyed. Reprint certain range of journal data specified by X record after they have been printed or cleared.

Accessing the LAST X PRINT(CONDENSED JOURNAL)

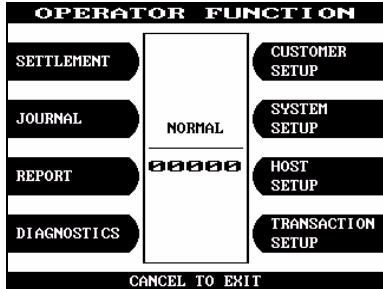

Select 'JOURNAL' in the OPERATOR FUNCTION menu.

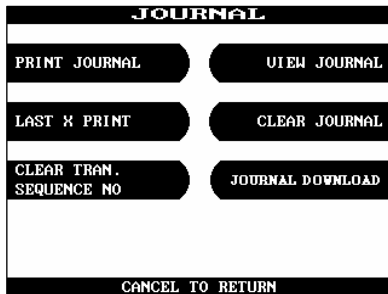

Select 'LAST X PRINT' in the JOURNAL menu.

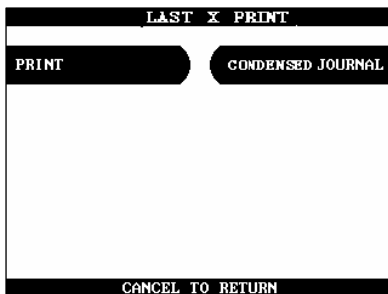

Select 'CONDENSED JOURNAL' in the LAST X PRINT menu.

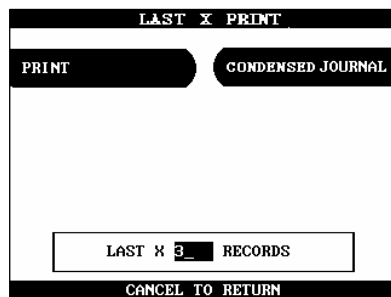

Enter the number of records to be printed. Wait while the Journal data is being printed.

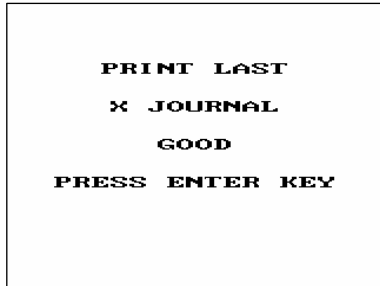

```
PRINT LAST
X JOURNAL
GOOD
PRESS ENTER KEY
```

If the GOOD message appears, press "ENTER".

Fig. 6.3.2 LAST X PRINT(CONDENSED JOURNAL)

Function Description

The LAST X PRINT(CONDENSED JOURNAL) function is used to reprint condensed records for which the paper trail has been lost or destroyed. Reprint as condensed certain range of journal data specified by X record after they have been printed or cleared.

6.3.3 View journal

Accessing the VIEW JOURNAL

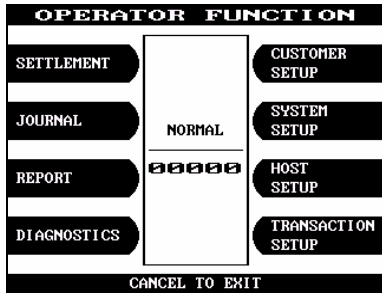

Select 'JOURNAL' in the OPERATOR FUNCTION menu.

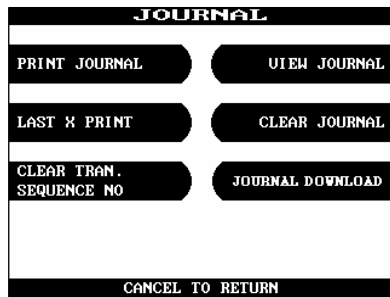

Select 'VIEW JOURNAL' in the JOURNAL menu.

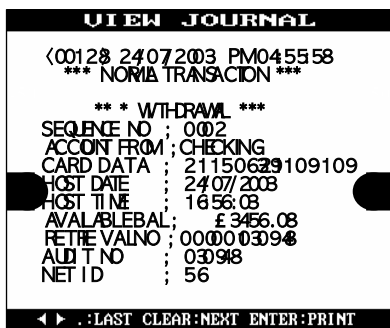

You may see the Journal Data which will be displayed on the screen.

Fig. 6.3.3 VIEW JOURNAL

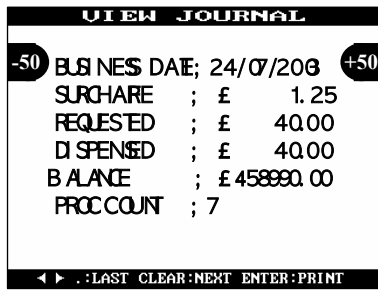

Fig. 6.3.3 VIEW JOURNAL

Function Description

The VIEW JOURNAL function is used to display the journal data in the LCD screen.

6.3.4 Clear journal

Accessing the CLEAR JOURNAL

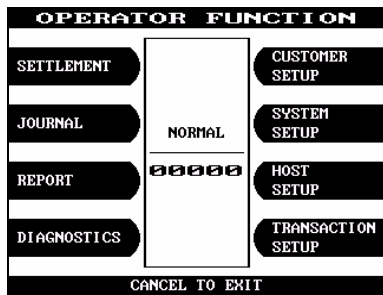

Select 'JOURNAL' in the OPERATOR FUNCTION menu.

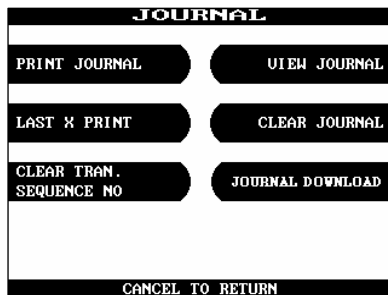

Select 'CLEAR JOURNAL' in the JOURNAL menu. The pointer of Journal data to print will be reset.

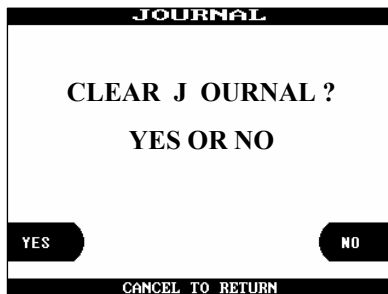

Fig. 6.3.4 CLEAR JOURNAL

Function Description

The CLEAR JOURNAL function is used to mark all records not printed in the journal. Journal records are not erased. They are marked as if they had been printed.

6.3.5 Clear tran. sequence NO.

Accessing the CLEAR TRAN. SEQUENCE NO.

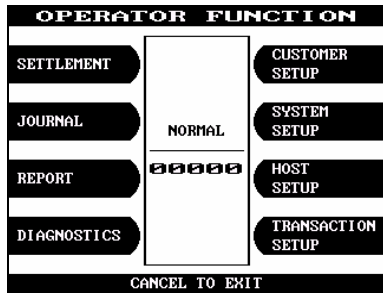

Select 'JOURNAL' in the OPERATOR FUNCTION menu.

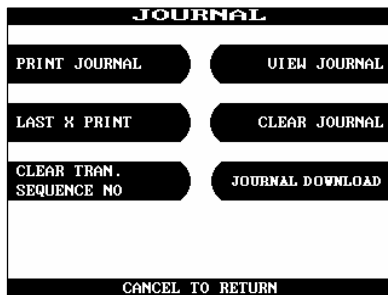

Select 'CLEAR TRAN. SEQUENCE NO.' in the JOURNAL menu.

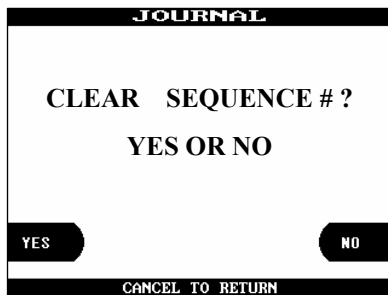

Fig. 6.3.5 CLEAR TRAN. SEQUENCE NO.

Function Description

The CLEAR TRAN. SEQUENCE NO. function is used to reset the transaction serial number as "1".

6.3.6 Journal download

Accessing the JOURNAL DOWN LOAD

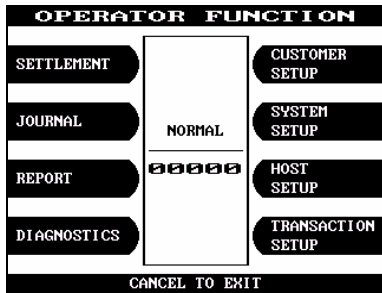

Select 'JOURNAL' in the OPERATOR FUNCTION menu.

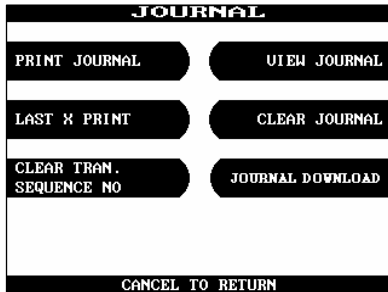

Select 'JOURNAL DOWNLOAD' in the JOURNAL menu.

Fig. 6.3.6 JOURNAL DOWNLOAD

Function Description

The JOURNAL DOWNLOAD function is not used currently.

6.4 Report

The Report function of the Operator Function includes the following :

ERROR CODE
MEMORY DUMP
S/W VERSION
PRINT ALL SETUP
ERROR SUMMARY
STATISTICS
REJECT ANALYSIS

6.4.1 Error code

Accessing the ERROR CODE

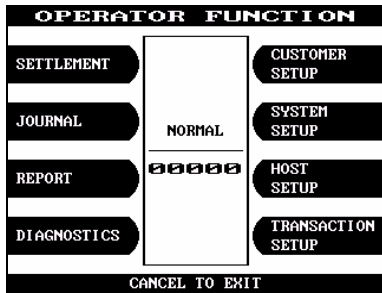

Select 'REPORT' in the OPERATOR FUNCTION menu.



Select 'ERROR CODE' in the REPORT menu.

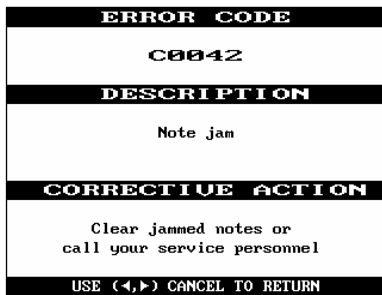

The Error code, description and corrective action will be displayed.

Fig. 6.4.1 ERROR CODE

Function Description

The ERROR CODE includes all error codes, descriptions and corrective actions. If an error occurs, the current error code will be displayed. To search the error code, use ←, → key.

6.4.2 Memory dump

Accessing the MEMORY DUMP

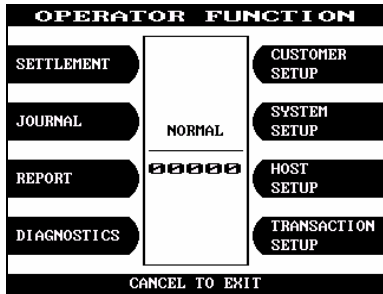

Select 'REPORT' in the OPERATOR FUNCTION menu.



Select 'MEMORY DUMP' in the REPORT menu.

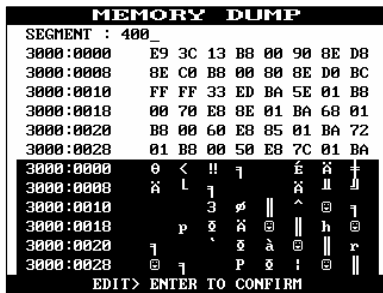

Dumped memory data will be displayed.

Fig. 6.4.2 MEMORY DUMP

Function Description

The MEMORY DUMP function is used to display the dumped memory data. This command is for use by the service engineers.

6.4.3 S/W version

Accessing the S/W VERSION

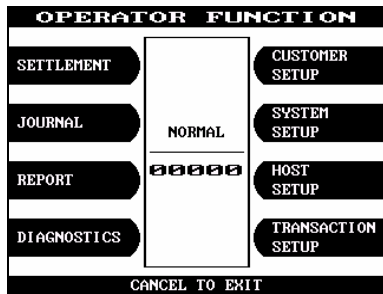

Select 'REPORT' in the OPERATOR FUNCTION menu.



Select 'S/W VERSION' in the REPORT menu.



Software Version will be displayed.

To print the Software Version information, press "ENTER".

Fig. 6.4.3 S/W VERSION

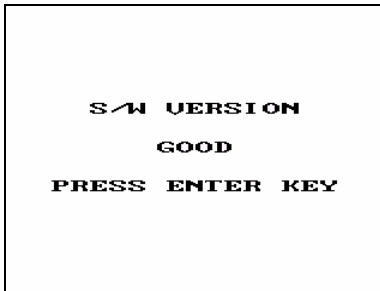

Software version will be printed from the receipt printer.

Fig. 6.4.3 S/W VERSION

Function Description

The S/W VERSION function is used to display each software version of system.

6.4.4 Print all setup

Accessing the PRINT ALL SETUP

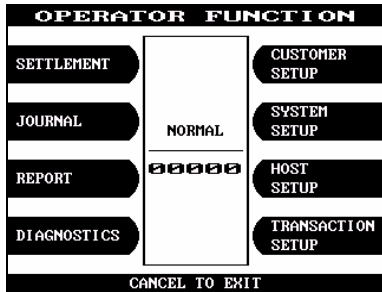

Select 'REPORT' in the OPERATOR FUNCTION menu.



Select 'PRINT ALL SETUP' in the REPORT menu.

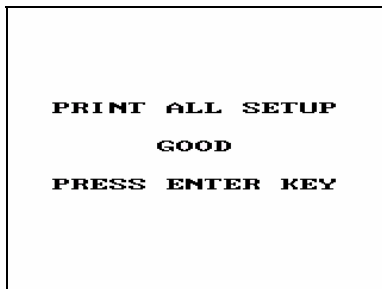

All setup parameters will be printed from the Receipt Printer. If the GOOD message appears, press "ENTER".

Fig. 6.4.4 PRINT ALL SETUP

Function Description

The PRINT ALL SETUP function is used to print all parameters of the system.

6.4.5 Error sum

Accessing the ERROR SUMMARY

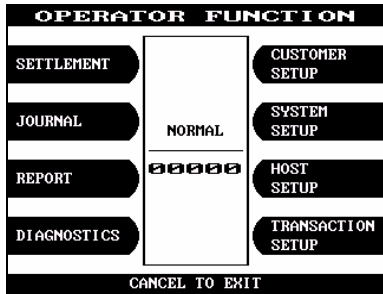

Select 'REPORT' in the OPERATOR FUNCTION menu.



Select 'ERROR SUM' in the REPORT menu.

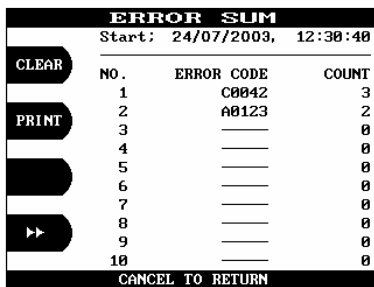

The error summary data will be displayed. Press "PRINT" key to print the Error Sum Data.

Fig. 6.4.5 ERROR SUMMARY

Function Description

The ERROR SUM function is used to display the error code and number of times the error occurred since the last ERROR SUM CLEAR. Therefore an operator can know which error occurs frequently and with this function it is useful for preventive maintenance. To clear all data, press "CLEAR".

6.4.6 Statistics

Accessing the STATISTICS

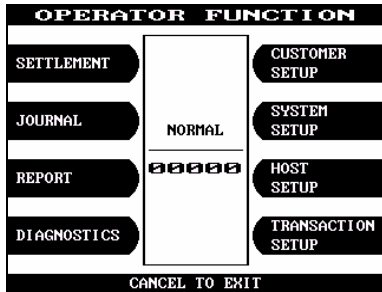

Select 'REPORT' in the OPERATOR FUNCTION menu.



Select 'STATISTICS' in the Report Menu.

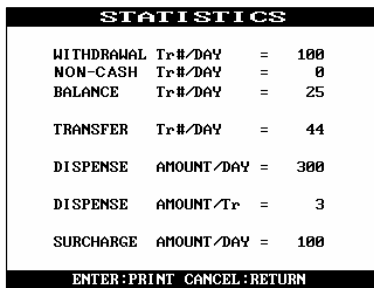

Statistics data will be displayed.
Press "ENTER" key to print data.

Fig. 6.4.6 STATISTICS

Function Description

The STATISTICS displays all transaction statistics data. To clear the data, press "CLEAR".

6.4.7 Reject analysis

Accessing the REJECT ANALYSIS

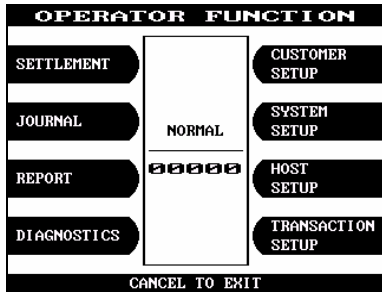

Select 'REPORT' in the OPERATOR FUNCTION menu.



Select 'REJECT ANALYSIS' in the REPORT menu.

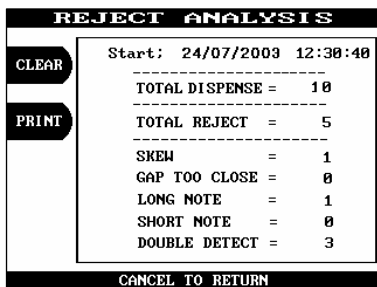

Reject Analysis data will be displayed.
Press "PRINT" key to print data.

Fig. 6.4.7 REJECT ANALYSIS

Function Description

The REJECT ANALYSIS function includes the analysis for the reason of the note reject and it is useful for the preventive maintenance.

6.5 Diagnostics

The Diagnostic function of Operator Function includes the following:

**INITIALIZE
RECEIPT PRINTER
CASH DISPENSER
MODEM
CARD SCAN
KEY MATRIX
SENSOR
AGING**

Changing the TEST COUNT

The TEST COUNT means the number of test.

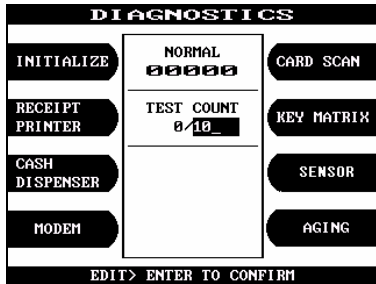

If you want to change the test count, press “CLEAR” then input the test count and press “ENTER”.

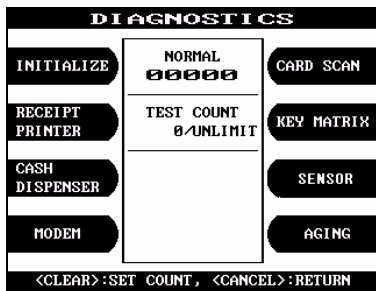

If you input ‘0 (zero)’, the test count will be changed to unlimited.

Fig. 6.5 CHANGING THE TEST COUNT

6.5.1 Initialize

Accessing the INITIALIZE

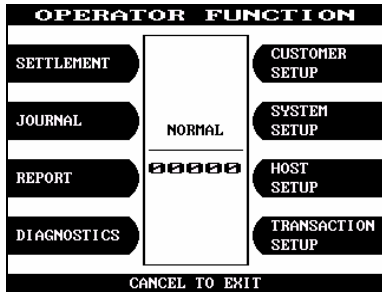

Select 'DIAGNOSTICS' in the OPERATOR FUNCTION.

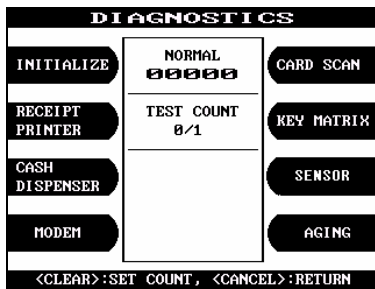

Select the 'INITIALIZE' in the DIAGNOSTICS menu. All units will be initialized.

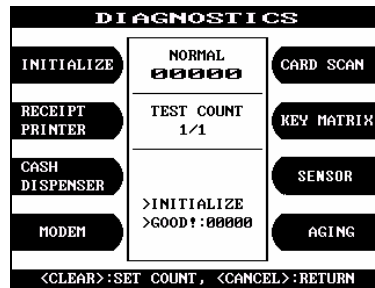

When the ATM is in the normal state, the GOOD message will be displayed.

Fig. 6.5.1 INITIALIZE

Function Description

The INITIALIZE has the function of resetting each unit of the Mini Bank 1500. If an error occurs while executing, the system will stop and display an error code. Confirm the detailed error description in the ERROR CODE of REPORT MENU.

6.5.2 Receipt printer

Accessing the RECEIPT PRINTER

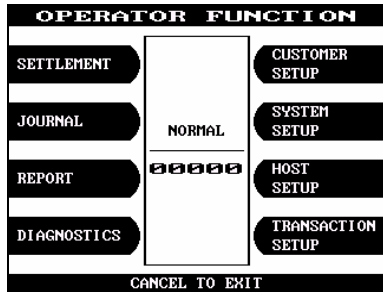

Select 'DIAGNOSTICS' in the OPERATOR FUNCTION.

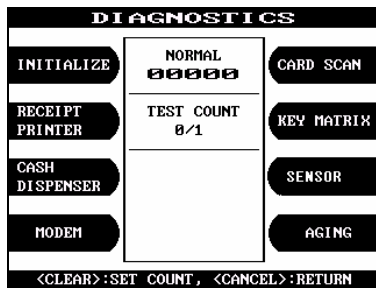

Select the 'RECEIPT PRINTER' in the DIAGNOSTICS menu.

Test String will be printed from the receipt printer.

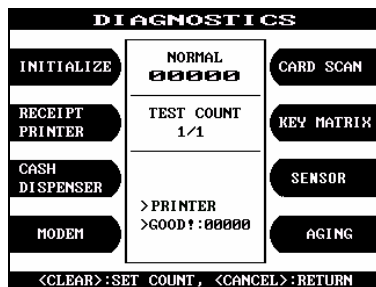

When the ATM is in the normal state, the GOOD message will be displayed.

Fig. 6.5.2 RECEIPT PRINTER

```

01234567890123456789012345678901234
!''#$$'()*+,-./01234
56789:;<=>?@ABCDEFGHIJKLMN
OPQRSTUVWXYZ[\^_`abcdefghijklmnop
ijklmnopqrstuvwxyz{|}~
01234567890123456789012345678901234

01234567890123456789012345678901234
!''#$$'()*+,-./01234
56789:;<=>?@ABCDEFGHIJKLMN
OPQRSTUVWXYZ[\^_`abcdefghijklmnop
ijklmnopqrstuvwxyz{|}~
01234567890123456789012345678901234

01234567890123456789012345678901234
!''#$$'()*+,-./01234
56789:;<=>?@ABCDEFGHIJKLMN
OPQRSTUVWXYZ[\^_`abcdefghijklmnop
ijklmnopqrstuvwxyz{|}~
01234567890123456789012345678901234

```

Fig. 6.5.2 A Sample of the print out from the RECEIPT PRINTER TEST

Function Description

The RECEIPT PRINTER has the function of printing a sample receipt and cutting out one receipt. If an error occurs while executing, the system will stop and display an error code. Confirm the detailed error description in the 4.4.1 ERROR CODE of REPORT MENU.

6.5.3 Cash dispenser

Accessing the CASH DISPENSER

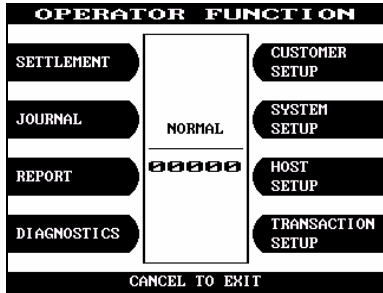

Select 'DIAGNOSTICS' in the OPERATOR FUNCTION.

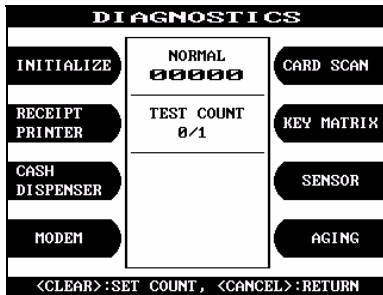

Select the 'CASH DISPENSER' in the DIAGNOSTICS menu.
The CASH DISPENSER test will be performed.

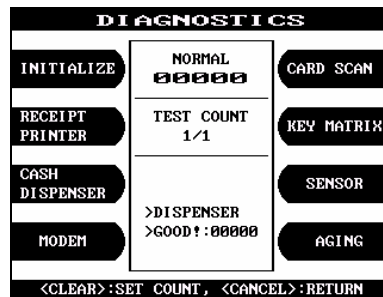

When the ATM is normal state, the GOOD message will be displayed.

Fig. 6.5.3 CASH DISPENSING UNIT

Function Description

The CASH DISPENSER has the function of testing the dispense mechanisms. This function will dispense one note from the cassette and dump into the reject bin. If an error occurs, the system will stop and display an error code. Confirm the detailed error description in the ERROR CODE of REPORT MENU.

6.5.4 Modem

Accessing the MODEM

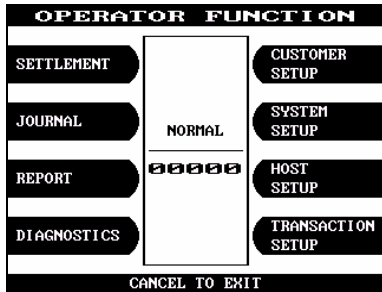

Select 'DIAGNOSTICS' in the OPERATOR FUNCTION.

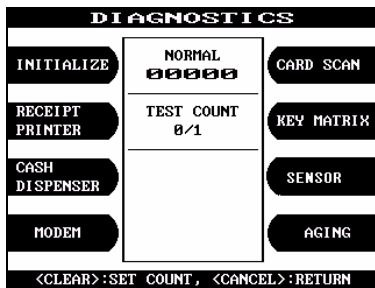

Select the 'MODEM' in the DIAGNOSTICS menu.



The MODEM TEST will be displayed.

Fig. 6.5.4 MODEM

Function Description

The MODEM has the function of testing the modem for any errors. When the phone number input is displayed after pressing the TEST DIAL key, input the desired phone number. The TEST DIAL function is used to check the function of the modem dial. The MODEM HANGUP function is used to hang-up the dialing after using TEST DIAL. If an error occurs, the system will stop and display an error code. Confirm the error description in the ERROR CODE MENU.

6.5.5 Card scan

Accessing the CARD SCAN

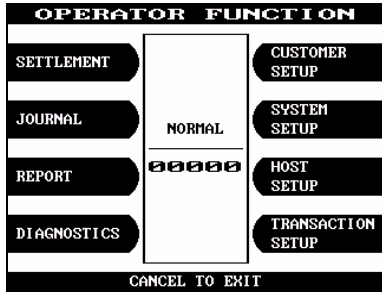

Select 'DIAGNOSTICS' in the OPERATOR FUNCTION.

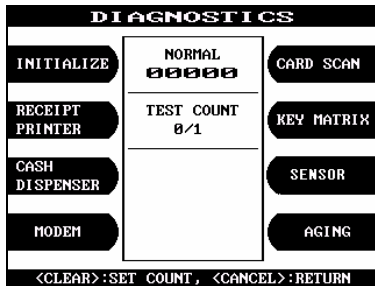

Select 'CARD SCAN' in the DIAGNOSTICS menu. And if the display is ready, please insert and remove the card quickly.

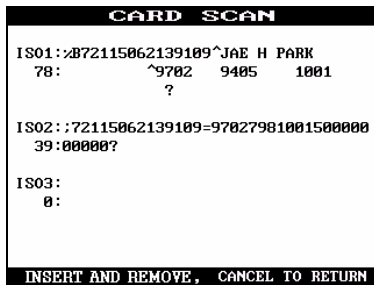

The card data will be displayed.

Fig. 6.5.5 CARD SCAN

Function Description

The CARD SCAN has the function of testing the magnetic stripe reader and the card itself.

6.5.6 Key matrix

Accessing the KEY MATRIX

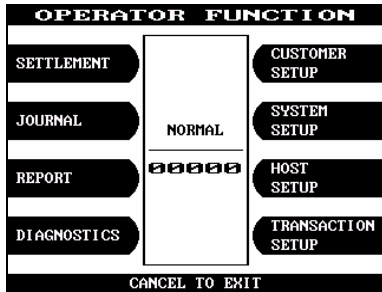

Select 'DIAGNOSTICS' in the OPERATOR FUNCTION.

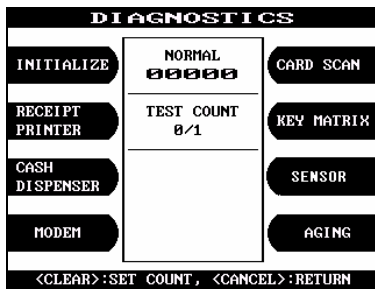

Select 'KEY MATRIX' in the DIAGNOSTICS menu.

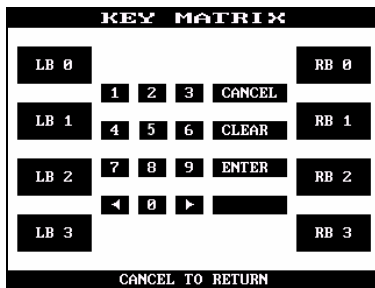

Select the desired key to be tested and the key being pressed will blink on the display.

Fig. 6.5.6 KEY MATRIX

Function Description

The KEY MATRIX has the function of testing the key pad.

6.5.7 Sensor

Accessing the SENSOR

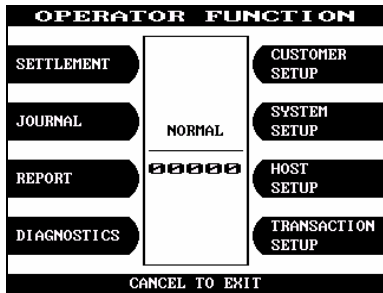

Select 'DIAGNOSTICS' in the OPERATOR FUNCTION.

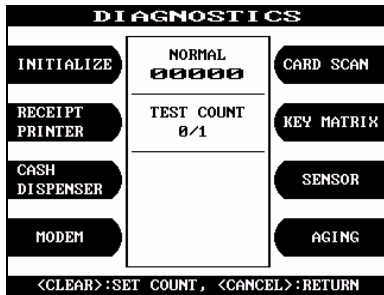

Select 'SENSOR' in the DIAGNOSTICS menu.

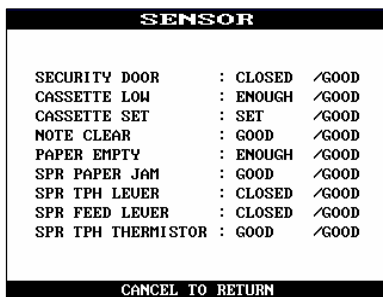

All SENSOR data will be displayed.

Fig. 6.5.7 SENSOR

Function Description

The SENSOR has the function of testing if all the sensors are in proper working condition. The sensors are tested by turning the sensors on and off.

6.5.8 Aging

Accessing the AGING

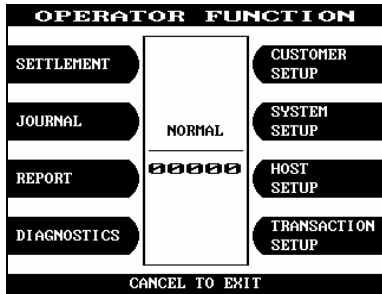

Select 'DIAGNOSTICS' in the OPERATOR FUNCTION.

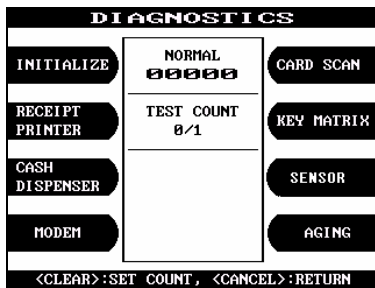

Select 'AGING' in the 'DIAGNOSTICS' menu.

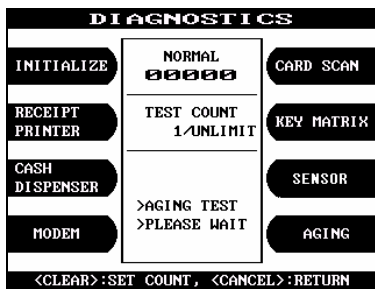

All units will be tested unlimitedly. When you press "CANCEL" key, the testing will be stopped.

Fig. 6.5.8 AGING

Function Description

The AGING function is only used at the factory. All units will be tested unlimitedly.

6.6 CUSTOMER SETUP

The Customer Setup function of the OPERATOR MENU includes the following :

CHANGE MESSAGE
WELCOME MESSAGE
RECEIPT HEADER
BIN LIST
SURCHARGE MODE
ADVERTISEMENT
OPTIONAL FUNCTION
RECEIPT SETUP
TRANS. OPTION
CONFIG CODE SET

6.6.1 Change message

6.6.1.1 WELCOME MESSAGE

Accessing the WELCOME MESSAGE

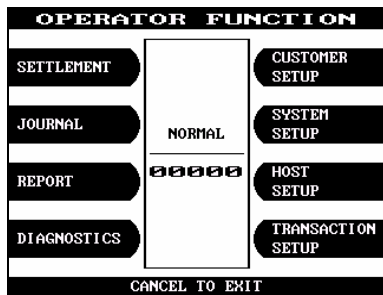

Select the 'CUSTOMER SETUP' in the OPERATOR FUNCTION menu.



Select the 'CHANGE MESSAGE' in the CUSTOMER SETUP menu.



Select the 'WELCOME MESSAGE' in the CHANGE MESSAGE menu.

Fig. 6.6.1.1 WELCOME MESSAGE



You can edit the welcome message.
Please refer to 6.1.2 How to use keypad.

Fig. 6.6.1.1 WELCOME MESSAGE

Function Description

The WELCOME MESSAGE function is used to edit the welcome text in “INSERT AND REMOVE YOUR CARD QUICKLY” screen. The factory default message is “WELCOME!!!”.

6.6.1.2 RECEIPT HEADER

Accessing the RECEIPT HEADER

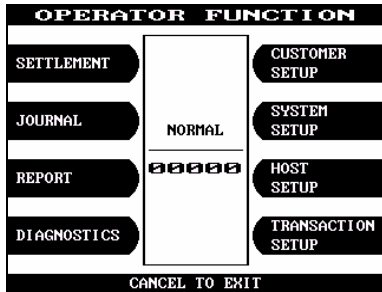

Select the 'CUSTOMER SETUP' in the OPERATOR FUNCTION menu.



Select the 'CHANGE MESSAGE' in the CUSTOMER SETUP menu.



Select the 'RECEIPT HEADER' in the CHANGE MESSAGE menu.

Fig. 6.6.1.2 RECEIPT HEADER



You can edit the RECEIPT HEADER.
Please refer to 5.1.2 How to use keypad.

Fig. 6.6.1.2 RECEIPT HEADER

Function Description

The RECEIPT HEADER function is used to edit the message at the header of receipt.
The factory default message is none.

6.6.2 Bin list

Accessing the BIN LIST

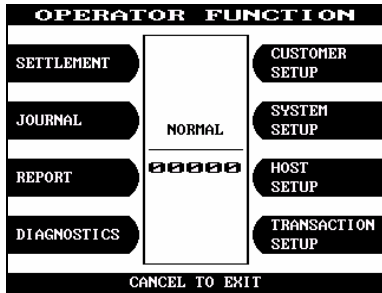

Select the 'CUSTOMER SETUP' in the OPERATOR FUNCTION menu.



Select the 'BIN LIST' in the CUSTOMER SETUP menu.

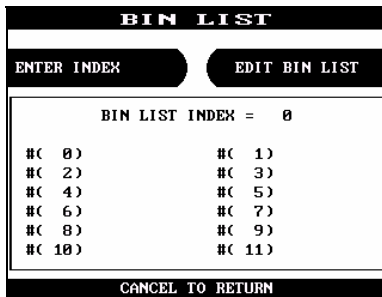

The BIN LIST menu will be displayed.

Fig. 6.6.2 BIN LIST

Function Description

The BIN LIST function is used to register bank lists and give bin codes not to surcharge the additional fee. But it is necessary to confirm the connected host because according to the host it can be used or not. After designating the INDEX, input a bin code with using "EDIT BIN LIST".

6.6.3 Surcharge mode

Accessing the SURCHARGE MODE

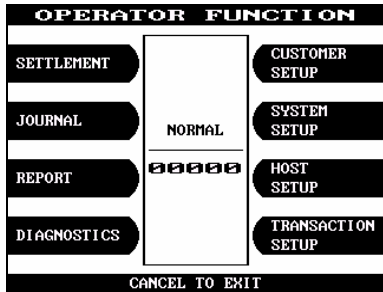

Select the 'CUSTOMER SETUP' in the OPERATOR FUNCTION menu.



Select the 'SURCHARGE MODE' in the CUSTOMER SETUP menu.

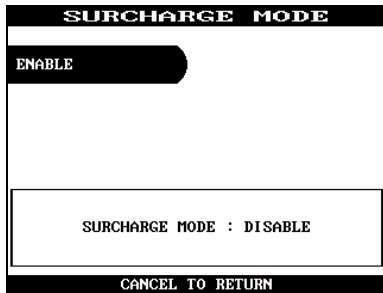

The SURCHARGE MODE menu will be displayed.

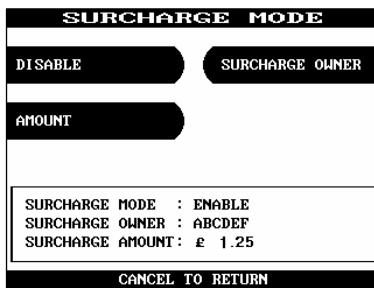

If you press the ENABLE key, it will be enabled as displayed.

Fig. 6.6.3 SURCHARGE MODE

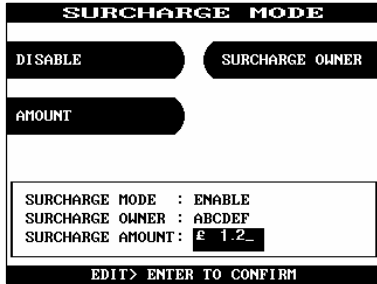

If you press the AMOUNT key, you can enter the desired surcharge amount.

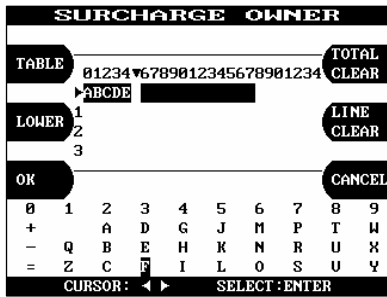

If you press the SURCHARGE OWNER key, you can enter the owner's name with keypad. Please refer to 5.1.2 How to use keypad.

Fig. 6.6.3 SURCHARGE MODE

Function Description

The SURCHARGE MODE includes the function to enable or disable the surcharge warning screen, setting the surcharge amount and surcharge owner. When the surcharge mode is disabled, the surcharge warning message will not be displayed and when the surcharge mode is enabled, the surcharge amount and owner name will be displayed in the surcharge warning screen. The factory default is disabled mode, surcharge amount is £ 0.00 and the surcharge owner is none.

6.6.4 Advertisement

Accessing the ADVERTISEMENT

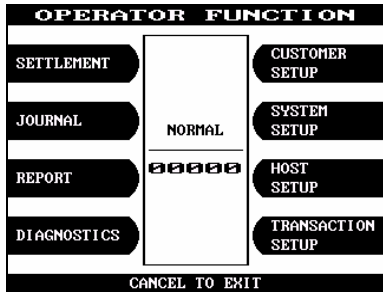

Select the 'CUSTOMER SETUP' in the OPERATOR FUNCTION menu.



Select the 'ADVERTISEMENT' in the CUSTOMER SETUP menu.

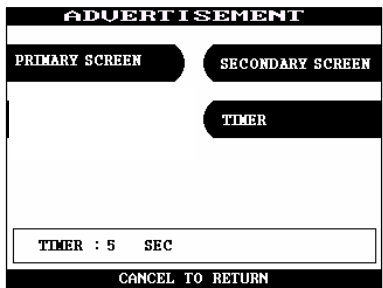

The ADVERTISEMENT menu will be displayed.

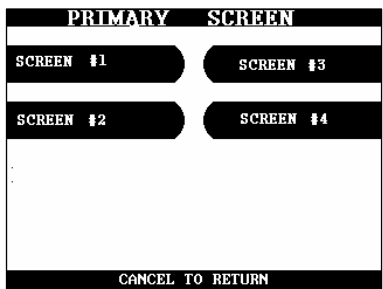

If you press the PRIMARY SCREEN key, the PRIMARY SCREEN will be displayed.

Select the 'SCREEN #1' in the PRIMARY SCREEN MENU.

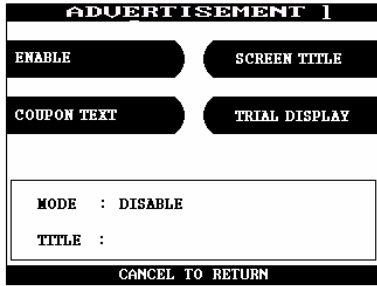

If you press the ENABLE/DISABLE key, it will be changed to be enabled or disabled.

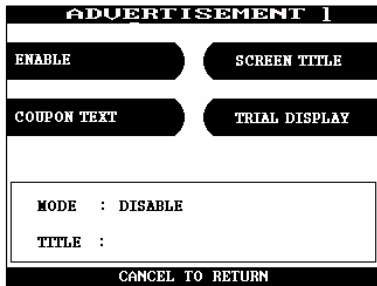

Select the 'SCREEN TITLE key' in the PRIMARY SCREEN MENU.

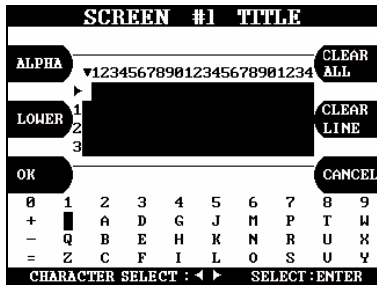

If you press the SCREEN TITLE key, you can enter the desired advertisement message. Please refer to 5.1.2 How to use keypad.

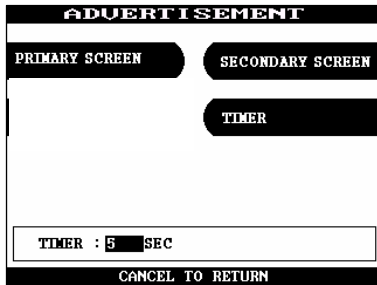

If you press the TIMER key, you can input the desired refreshing timer of advertisement text.

Function Description

The ADVERTISEMENT function is used to set the advertisement message displayed during idle time, such as “INSERT AND REMOVE YOUR CARD QUICKLY” and “PLEASE WAIT CONNECTING”. The factory default is disabled mode, 3 seconds and no message. But if there is no message, “HAVE A NICE DAY” will be displayed in the bottom of screen.

6.6.5 Optional function

Accessing the OPTIONAL FUNCTION

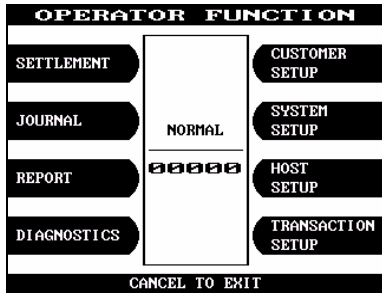

Select the 'CUSTOMER SETUP' in the OPERATOR FUNCTION menu.



Select the 'OPTIONAL FUNCTION' in the CUSTOMER SETUP menu.

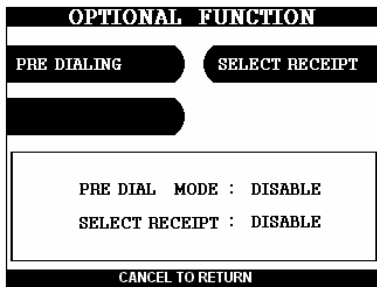

Select the 'PRE DIALING' in the OPTIONAL FUNCTION menu.

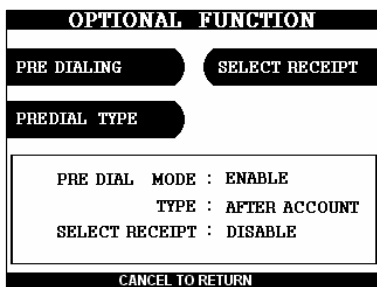

If you press the PRE DIALING key, you can change the desired pre-dialing mode.

The screenshot shows a terminal-style interface for the 'OPTIONAL FUNCTION' menu. At the top, the title 'OPTIONAL FUNCTION' is displayed. Below it, there are two main options: 'PRE DIALING' and 'SELECT RECEIPT'. Each option has a corresponding status indicator below it. The status for 'PRE DIAL MODE' is 'DISABLE', and the status for 'SELECT RECEIPT' is also 'DISABLE'. At the bottom of the screen, there is a prompt 'CANCEL TO RETURN'.

If you Select the 'SELECT RECEIPT' in the OPTIONAL FUNCTION MENU, it will be changed to be enabled or disabled.

Function Description

The 'OPTIONAL FUNCTION' function is used to set PRE-DIALING and set RECEIPT.

6.6.6 Trans. option

Accessing the TRANS. OPTION

Select the 'CUSTOMER SETUP' in the OPERATOR FUNCTION menu.

Select the 'TRANS. OPTION' in the CUSTOMER SETUP menu.

If you press the 'CREDIT CARD' and 'SAVINGS' key, it will be changed to be enabled or disabled.

Function Description

The 'CREDIT CARD' and 'SAVINGS' functions are used to set Account.

6.6.7 Config code set

Accessing the CONFIG CODE SET

Select the 'CUSTOMER SETUP' in the OPERATOR FUNCTION menu.

Select the 'CONFIG CODE SET' in the CUSTOMER SETUP menu.

Insert the desired Terminal Configuration Number and press ENTER key.

Function Description

The 'TERMINAL CONFIG NO' function is used to set Terminal Configuration Number.

6.7 System setup

The SYSTEM SETUP function of the OPERATOR FUNCTION includes the following:

SET CLOCK
ISO #1, #2, #3 EN/DISABLE
LANGUAGE EN/DISABLE
CHANGE PASSWORD
MODEM
 MODEM SETUP
 DIAL MODE
 MODEM SPEED
 SPEAKER OUT
 INITIAL STRING
 MODEM TEST
RMS RING COUNT
SPEAKER VOLUME

6.7.1 Set clock

Accessing the SET CLOCK

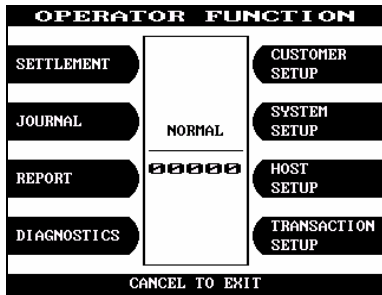

Select the 'SYSTEM SETUP' in the OPERATOR FUNCTION menu.

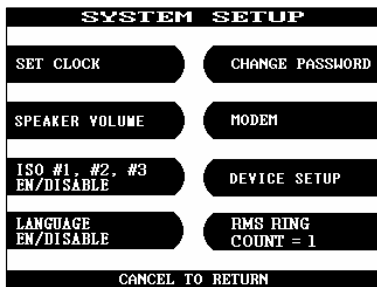

Select the 'SET CLOCK' in the SYSTEM SETUP menu.



The SET CLOCK menu will be displayed.

Fig. 6.7.1 SET CLOCK

Function Description

The SET CLOCK function is used to set the date and clock. When the "SECOND" key is pressed, the second will be reset to "0".

6.7.2 ISO #1, #2, #3 en/disable

Accessing the ISO #1, #2, #3 EN/DISABLE

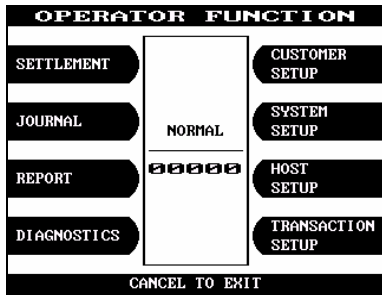

Select the 'SYSTEM SETUP' in the OPERATOR FUNCTION menu.

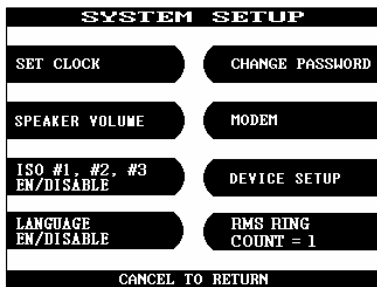

Select the 'ISO #1, #2, #3 EN/DISABLE' in the SYSTEM SETUP menu.

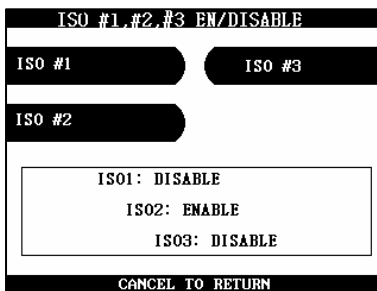

If you press the ISO #1, #2, #3 key, it will be changed to be enabled or disabled.

Fig. 6.7.2 ISO #1, #2, #3 EN/DISABLE

Function Description

The ISO #1, #2, #3 EN/DISABLE includes the function to enable or disable the ISO warning screen. Each key will be changed to be enabled or disabled.

6.7.3 Language en/disable

Accessing the LANGUAGE EN/DISABLE

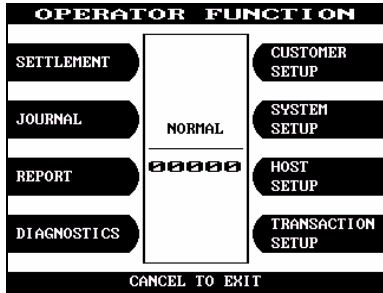

Select the 'SYSTEM SETUP' in the OPERATOR FUNCTION menu.

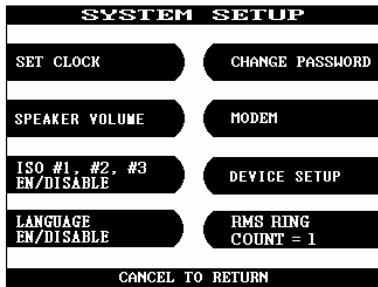

Select the 'LANGUAGE EN/DISABLE' in the SYSTEM SETUP menu.



If you press the ENGLISH or SPANISH or KOREAN or JAPANESE key, it will be changed to be enabled or disabled.

Fig. 6.7.3 LANGUAGE EN/DISABLE

Function Description

The LANGUAGE EN/DISABLE key includes the function to enable or disable the LANGUAGE warning screen. Each key will be changed to be enabled or disabled.

6.7.4 Change password

Accessing the CHANGE PASSWORD

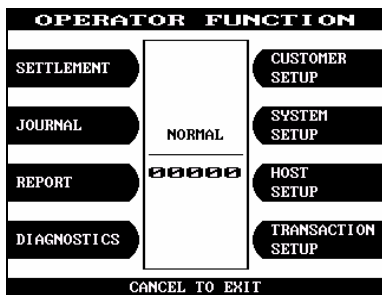

Select the 'SYSTEM SETUP' in the OPERATOR FUNCTION menu.

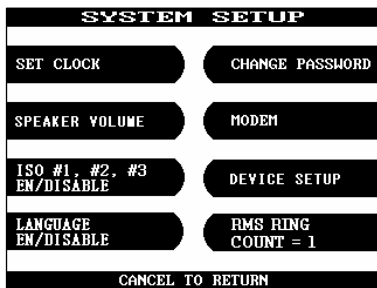

Select the 'CHANGE PASSWORD' in the SYSTEM SETUP menu.



Select the 'MASTER PASSWORD' or the 'OPERATOR PASSWORD' or the 'SERVICE PASSWORD' in the CHANGE PASSWORD.

Enter the current Operator Password.

Fig. 6.7.4 CHANGE PASSWORD

CHANGE PASSWORD

OPERATOR PASSWORD SERVICE PASSWORD

MASTER PASSWORD

ENTER NEW PASSWORD
[* * * * *]

EDIT> ENTER TO CONFIRM

Enter the new Operator Password or the new Master Password.

CHANGE PASSWORD

OPERATOR PASSWORD SERVICE PASSWORD

MASTER PASSWORD

VERIFY PASSWORD
[* * * * *]

EDIT> ENTER TO CONFIRM

Enter the new Operator Password or the new Master Password again.

CHANGE PASSWORD

OPERATOR PASSWORD SERVICE PASSWORD

MASTER PASSWORD

PASSWORD CHANGED

EDIT> ENTER TO CONFIRM

The password will be changed.

Fig. 6.7.4 CHANGE PASSWORD

Function Description

The CHANGE PASSWORD function is used to change the Operator Password.
 The factory default Operator Password is “159951”..
 The factory default Master Password is “375876”..
 The factory default Service Password is “965733”.

6.7.5 Modem

6.7.5.1 MODEM SETUP

1) DIAL MODE

Accessing the DIAL MODE

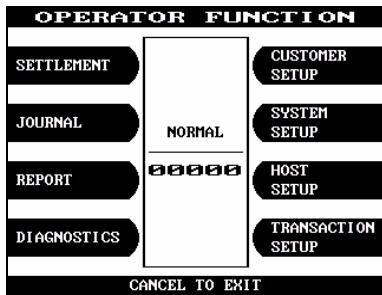

Select the 'SYSTEM SETUP' in the OPERATOR FUNCTION menu.

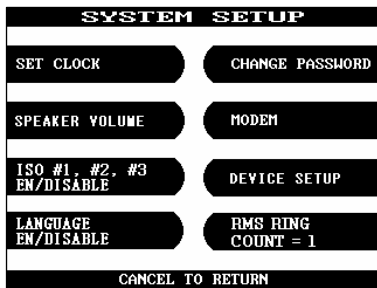

Select the 'MODEM' in the SYSTEM SETUP menu.

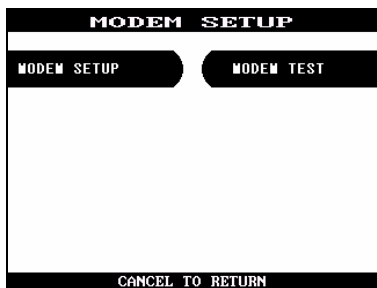

Select the 'MODEM SETUP' in the MODEM menu.

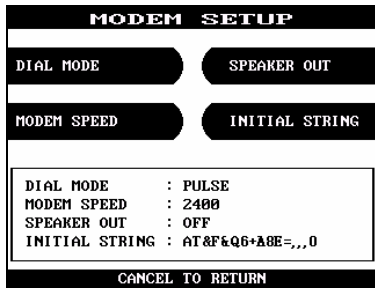

When the DIAL MODE is pressed , the DIAL MODE will be changed to DTMF or PULSE.

Fig. 6.7.5.1.1 DIAL MODE

Function Description

The DIAL MODE function is used to change the Dial Mode to touch-tone mode(DTMF) or rotary mode(PULSE). Consult with the local phone company to determine which option is supported. The factory default is DTMF.

2) Modem speed

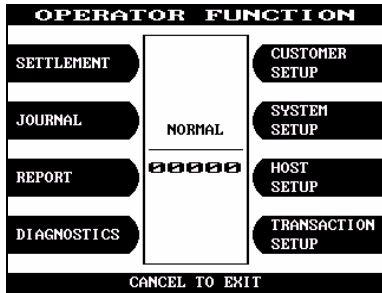
Accessing the MODEM SPEED

Select the 'SYSTEM SETUP' in the OPERATOR FUNCTION menu.

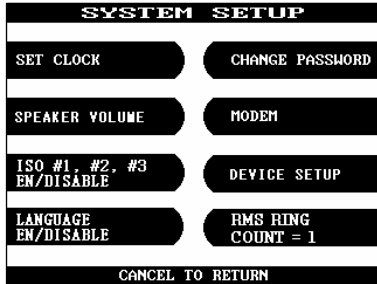

Select the 'MODEM' in the SYSTEM SETUP menu.

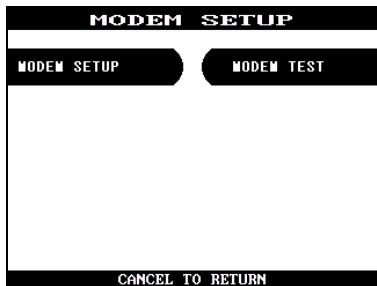

Select the 'MODEM SETUP' in the MODEM menu.

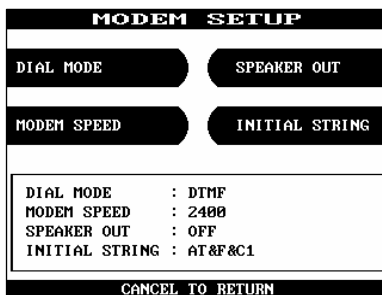

Select the 'MODEM SPEED' in the MODEM SETUP menu.

MODEM SETUP	
DIAL MODE	SPEAKER OUT
MODEM SPEED	INITIAL STRING
DIAL MODE : DTMF	
MODEM SPEED : 9600	
SPEAKER OUT : OFF	
INITIAL STRING : AT&F&C1	
CANCEL TO RETURN	

The Modem Speed can be changed from 300bps up to 56,600bps.

Fig. 6.7.5.1..2 MODEM SPEED

Function Description

The MODEM SPEED function is used to set the modem connecting speed with the host. The factory default speed is 2400bps.

3) Speaker out

Accessing the SPEAKER OUT

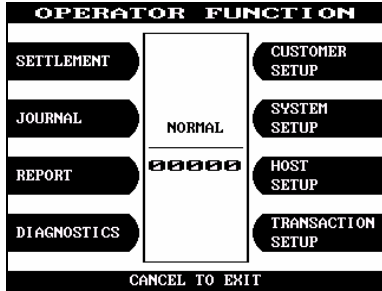

Select the 'SYSTEM SETUP' in the OPERATOR FUNCTION menu.

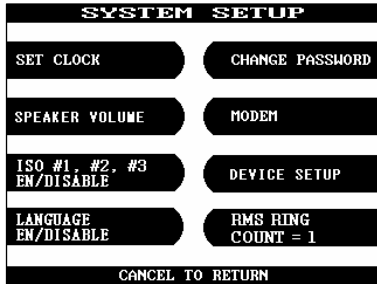

Select the 'MODEM' in the SYSTEM SETUP menu.

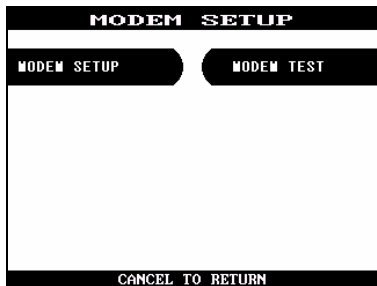

Select the 'MODEM SETUP' in the MODEM MENU.

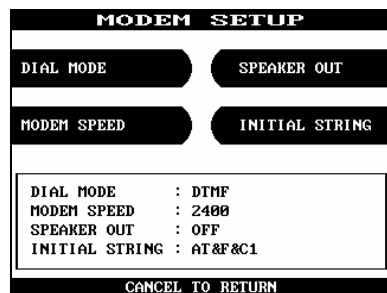

Select the 'SPEAKER OUT' in the MODEM SETUP menu.

When you press the Speaker Out key, you can change speaker out on or off.

Fig. 6.7.5.1.3 SPEAKER OUT

Function Description

The SPEAKER OUT function is used to change the speaker out on or off at the modem dial connection. Service Personnel can check the dialing if it is normal or abnormal with this function in the speaker out on state. The factory default is OFF.

4) Initial string

Accessing the INITIAL STRING

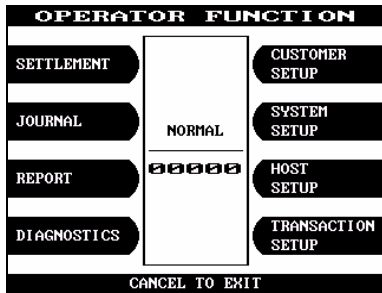

Select the 'SYSTEM SETUP' in the OPERATOR FUNCTION menu.

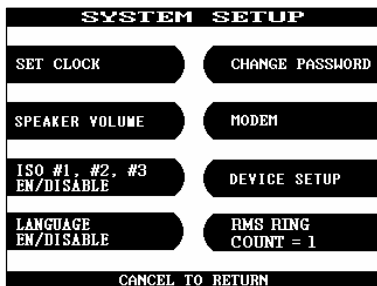

Select the 'MODEM' in the SYSTEM SETUP menu.

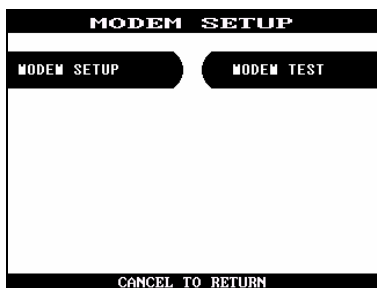

Select the 'MODEM SETUP' in the MODEM menu.

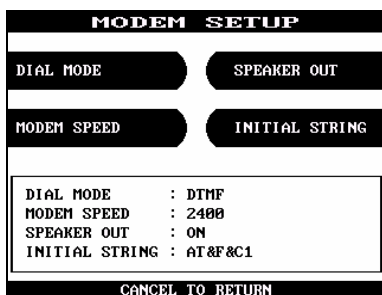

Select the 'INITIAL STRING' in the MODEM SETUP menu.

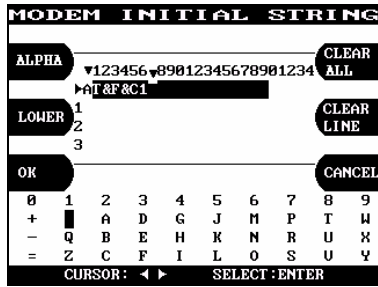

Enter the desired modem initial string.
Please refer to 6.1.2 How to use keypad.

Fig. 6.7.5.1..4 INITIAL STRING

Function Description

The INITIAL STRING function is used to edit the Modem Initial String when the special circumstances require a nonstandard Modem Initial String. The factory default is AT&F&C1. Before edit the Initial String, consult with Service Personnel.

6.7.5.2 Modem test

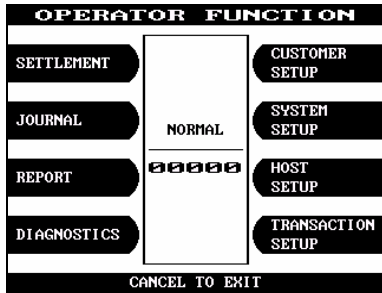
Accessing the MODEM TEST

Select the 'SYSTEM SETUP' in the OPERATOR FUNCTION menu

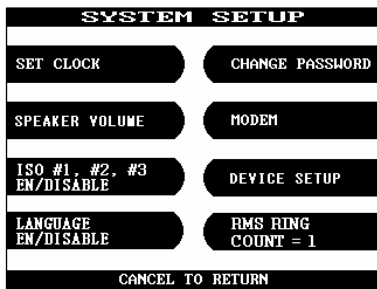

Select the 'MODEM' in the SYSTEM SETUP menu. The modem will be started to test.

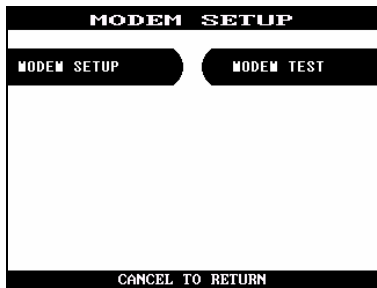

Select the 'MODEM TEST' in the MODEM menu.

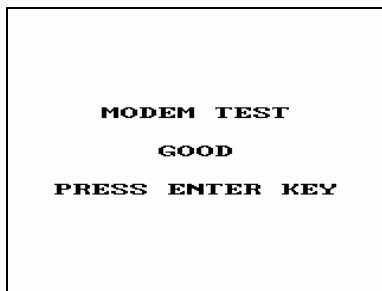

If the GOOD message appears, press "ENTER".

Fig. 6.7.5.2 MODEM TEST

Function Description

The MODEM TEST function is used to perform the modem reset test.

When the error is occurred, contact the Service Personnel.

6.7.6 RMS ring count

Accessing the RMS RING COUNT

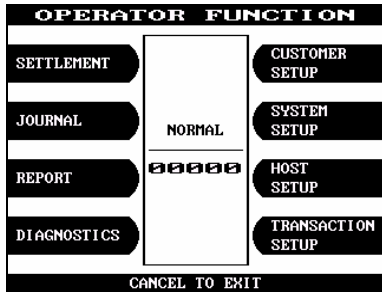

Select the 'SYSTEM SETUP' in the OPERATOR FUNCTION menu.

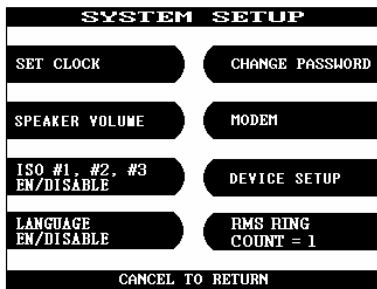

Select the 'RMS RING COUNT' in the SYSTEM SETUP menu.

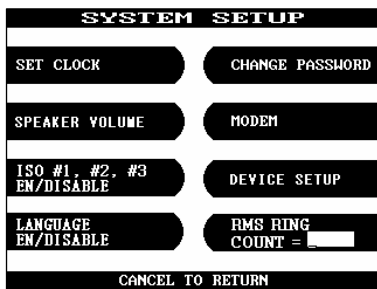

Input the RMS RING COUNT and press 'ENTER'.

Fig. 6.7.8 RMS RING COUNT

Function Description

When RMS calls to ATM, ATM will answer to RMS after ringing as RMS RING COUNT.

6.7.7 Speaker volume

Accessing the SPEAKER VOLUME

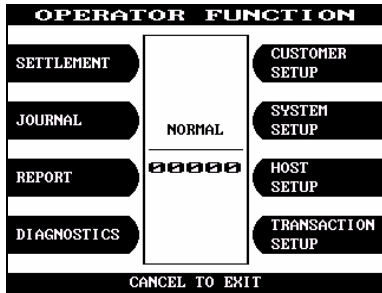

Select the 'SYSTEM SETUP' in the OPERATOR FUNCTION menu.

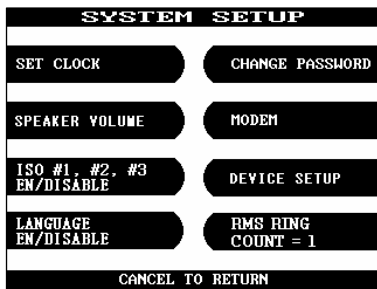

Select the 'SPEAKER VOLUME' in the SYSTEM SETUP menu.



Set your speaker volume with using <, > key.

Fig. 6.7.2 SPEAKER VOLUME

Function Description

The SPEAKER VOLUME function is used to set the speaker volume. With using <, > key an operator can hear the beep sound.

6.8 Host setup

The HOST SETUP function of the OPERATOR FUNCTION includes the following:

KEY MANAGEMENT
 MASTER KEY INDEX
 CHECK MASTER KEY
 EDIT MASTER KEY
 SET MASTER KEY SERIAL NUMBER
TELEPHONE NUMBER
ID SETUP
 TERMINAL NUMBER
 ROUTING ID
 NET. USER ADDR
HEARTBEAT INTERVAL MESSAGE
CONNECT TIMER 60 SECOND
REMOTE MONITOR
 RMS EN/DISABLE
 RMS STATUS SEND EN/DISABLE
 PASSWORD
 REMOTE PHONE
 MODEM SPEED
COMM. KEY D/N
CLOSE TIME

6.8.1 Key management

6.8.1.1 Master key index

Accessing the MASTER KEY INDEX

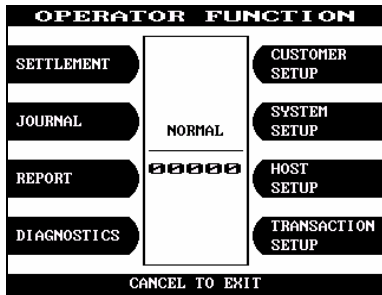

Select the 'HOST SETUP' in the OPERATOR FUNCTION menu.

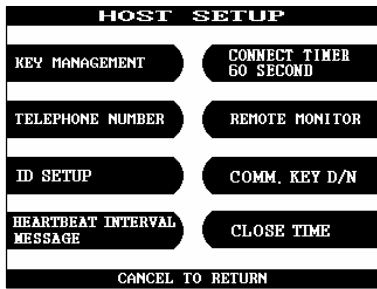

Select the 'KEY MANAGEMENT' in the HOST SETUP menu.



Select the 'MASTER KEY INDEX' in the KEY MANAGEMENT menu.
Enter the Master Key Index.

Fig. 6.8.1.1 MASTER KEY INDEX

Function Description

The MASTER KEY INDEX function is used to set the Master Key Index. The range is 0 to 15.

6.8.1.2 Check master key

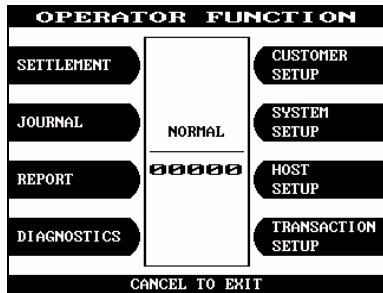
Accessing the CHECK MASTER KEY

Select the 'HOST SETUP' in the OPERATOR FUNCTION menu.

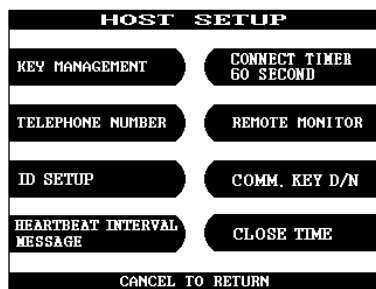

Select the 'KEY MANAGEMENT' in the HOST SETUP menu.



Select the 'CHECK MASTER KEY' in the KEY MANAGEMENT menu.

Fig. 6.8.1.2 CHECK MASTER KEY

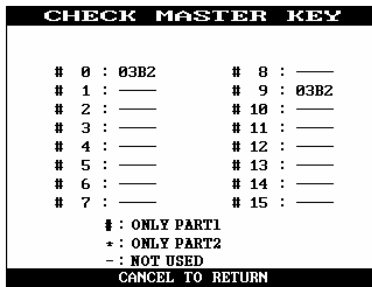

It will display the check sum of all injected master key.

Fig. 6.8.1.2 CHECK MASTER KEY

Function Description

The CHECK MASTER KEY function is used to display the check sum of all injected Master Key. The master key which is displayed as “_____” means it is in empty state.

6.8.1.3 Edit master key

Accessing the EDIT MASTER KEY

Select the 'HOST SETUP' in the OPERATOR FUNCTION menu.

Select the 'KEY MANAGEMENT' in the HOST SETUP menu.

Select the 'EDIT MASTER KEY' in the KEY MANAGEMENT menu.

Select the 'MASTER KEY PART1' or 'MASTER KEY PART2' in the EDIT MASTER KEY menu.

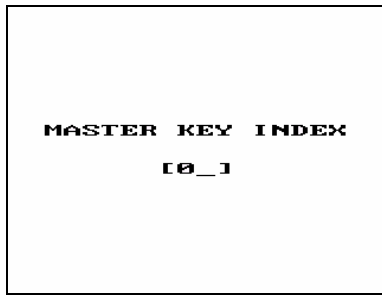

Enter the master key index.



Enter the Master Key PART 1.



Verify the Master Key PART 1.



Enter the Master Key PART 2

Fig. 6.8.1.3 EDIT MASTER KEY

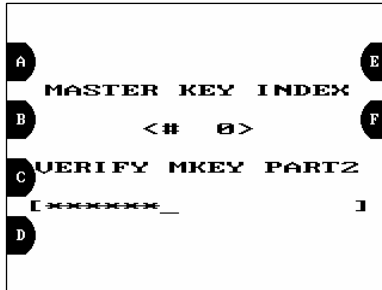

Verify the Master Key PART 2.

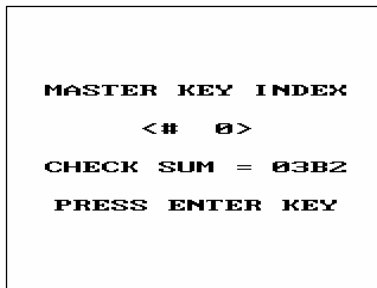

After inputting the Master Key, the check sum will be displayed. Press “ENTER” after confirming the check sum.

Fig. 6.8.1.3 EDIT MASTER KEY

Function Description

The EDIT MASTER KEY function is used to enter the Master Key.

6.8.1.4 Set master key serial number

Accessing the SET MASTER KEY SERIAL NUMBER

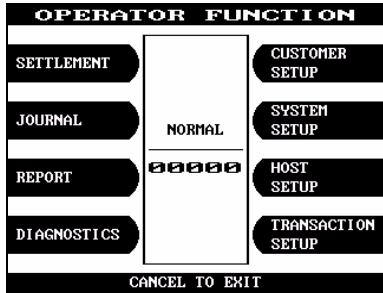

Select the 'HOST SETUP' in the OPERATOR FUNCTION menu.

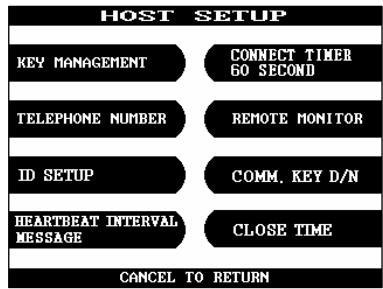

Select the 'KEY MANAGEMENT' in the HOST SETUP menu.



Select the 'MASTER KEY SERIAL NUMBER' in the KEY MANAGEMENT menu.
And insert serial number.

Fig. 6.8.1.4 MASTER KEY SERIAL NUMBER

Function Description

The MASTER KEY SERIAL NUMBER function is used to insert the ATM machine number for RMS (Mono : 1400000001 ~ 1499999999, Color : 1500000001 ~ 1599999999).

6.8.2 Telephone number

Accessing the TELEPHONE NUMBER

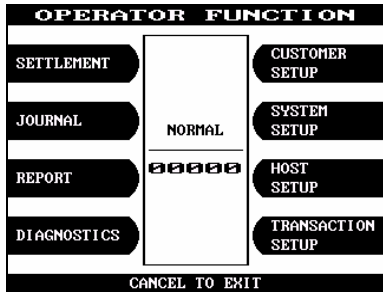

Select the 'HOST SETUP' in the OPERATOR FUNCTION menu.



Select the 'TELEPHONE NUMBER' in the HOST SETUP menu.

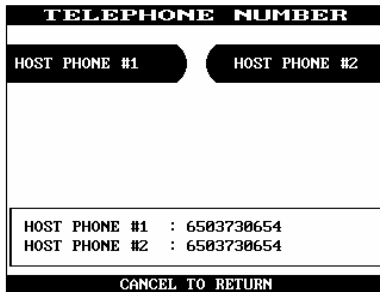

Select the 'HOST PHONE #1' in the TELEPHONE NUMBER menu.

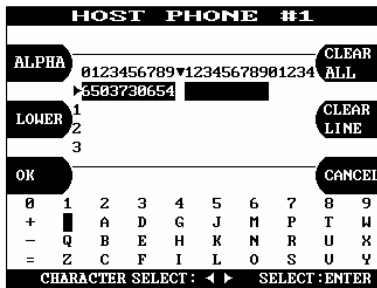

Enter the Host Phone number 1.
Please refer to 5.1.2 How to use keypad.

Fig. 6.8.2 TELEPHONE NUMBER

TELEPHONE NUMBER

HOST PHONE #1 HOST PHONE #2

HOST PHONE #1 : 6503730654
 HOST PHONE #2 : 6503730654

CANCEL TO RETURN

Select the 'HOST PHONE #2' in the TELEPHONE NUMBER MENU.

HOST PHONE #2

ALPHA TOTAL CLEAR

123456789012345678901234

6503730654

LOWER LINE CLEAR

1
2
3

OK CANCEL

0	1	2	3	4	5	6	7	8	9
([{	<	,	!	'	%	:	?
)]	}	>	.	\$	"	*	;	/

CHARACTER SELECT: ◀ ▶ SELECT: ENTER

Enter the Host Phone number 2.
 Please refer to 5.1.2 how to use keypad.

Fig. 6.8.2 TELEPHONE NUMBER

Function Description

The TELEPHONE NUMBER function is used to enter the Primary Telephone Number and the Back-up Telephone number of the host.

6.8.3 ID setup

6.8.3.1 Terminal number

Accessing the TERMINAL NUMBER

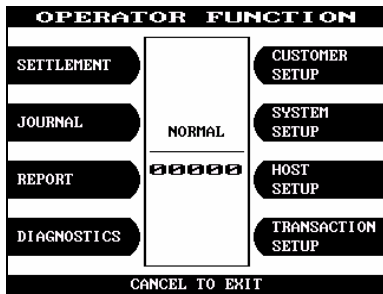

Select the 'HOST SETUP' in the OPERATOR FUNCTION menu.



Select the 'ID SETUP' in the HOST SETUP menu.

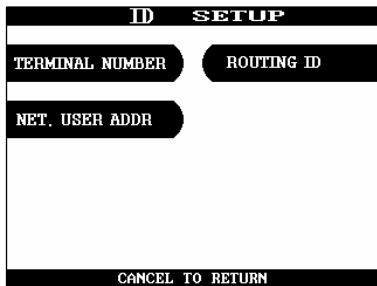

Select the 'TERMINAL NUMBER' in the ID SETUP menu.

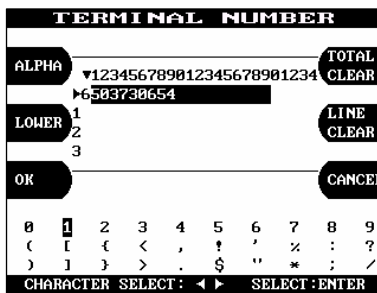

Enter the Terminal Number.
Please refer to 5.1.2 how to use keypad.

Fig. 6.8.3 TERMINAL NUMBER

Function Description

The TERMINAL NUMBER function is used to set the Terminal Number of Mini Bank 1500.

6.8.3.2 Routing ID

Accessing the ROUTING ID

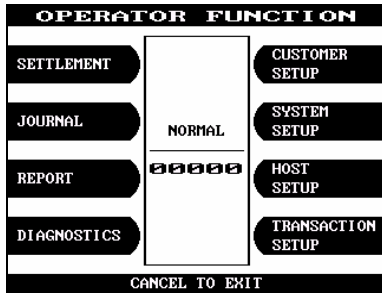

Select the 'HOST SETUP' in the OPERATOR FUNCTION menu.



Select the 'ID SETUP' in the HOST SETUP menu.

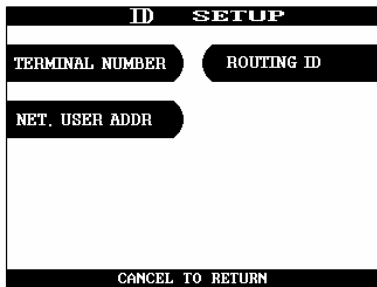

Select the 'ROUTING ID' in the ID SETUP menu.

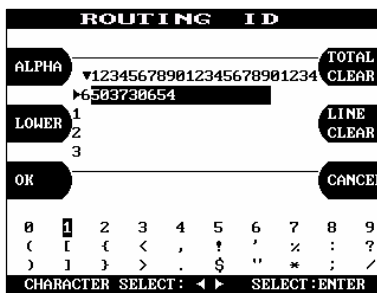

Enter the desired Routing ID number. Please refer to 5.1.2 How to use keypad.

Fig. 6.8.4 ROUTING ID

Function Description

The ROUTING ID function is used to set the Routing ID Number of Mini Bank 1500.

6.8.3.3 Net user addr.

Accessing the NET. USER ADDR

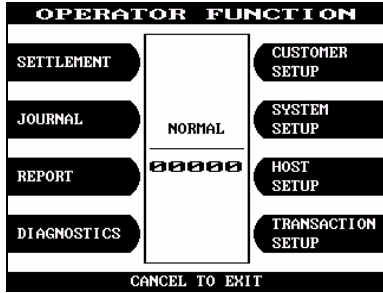

Select the 'HOST SETUP' in the OPERATOR FUNCTION menu.

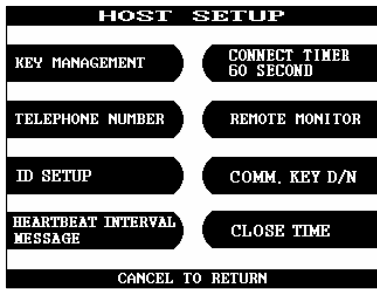

Select the 'ID SETUP' in the HOST SETUP menu.

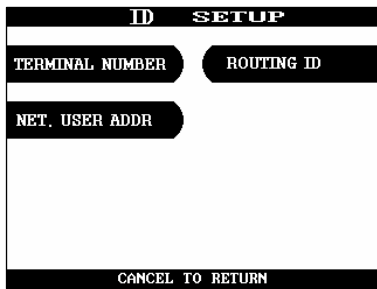

Select the 'NET. USER ADDR' in the ID SETUP menu.

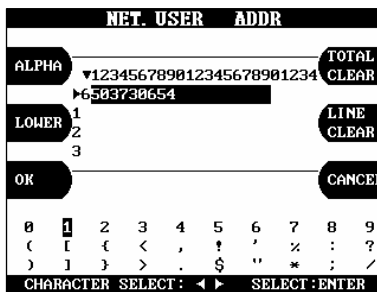

Enter the desired NET. USER ADDR number. Please refer to 5.1.2 How to use keypad.

Fig. 6.8.5 NET. USER ADDR

Function Description

The NET. USER ADDR function is used to set the NETWORK USER ADDRESS Number of Mini bank 1500.

6.8.4 Heartbeat interval message

Accessing the HEARTBEAT INTERVAL MESSAGE

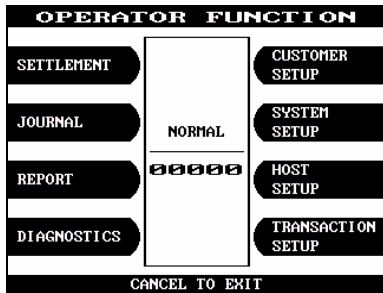

Select the 'HOST SETUP' in the OPERATOR FUNCTION menu.



Select the 'HEARTBEAT INTERVAL MESSAGE' in the HOST SETUP menu.

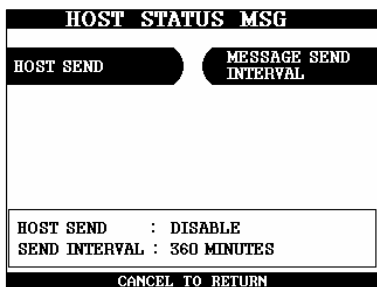

Select the 'HOST SEND' and 'MESSAGE SEND INTERVAL' in the HEARTBEAT INTERVAL MESSAGE menu.

Fig. 6.8.6 HEARTBEAT INTERVAL MESSAGE

Function Description

The HOST SEND function is used to set HOST SEND MESSAGE to be enabled or disabled.

The MESSAGE SEND INTERVAL function is used to set INTERVAL TIME.

6.8.5 Connect timer 60 second

Accessing the CONNECT TIMER 60 SECOND

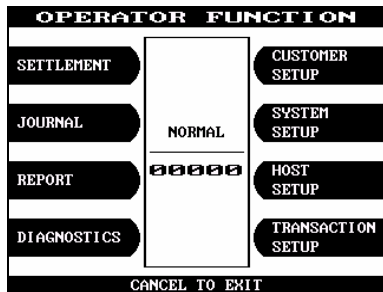

Select the 'HOST SETUP' in the OPERATOR FUNCTION menu.



Select the 'CONNECT TIMER 60 SECOND' in the HOST SETUP menu. After inputting the timer parameter, press "ENTER".

Fig. 6.8.7 CONNECT TIMER

Function Description

The CONNECT TIMER 60 SECOND function is used to set the waiting timer during connecting to the host. After powering on the machine, the machine will try to connect to the host. However when the machine fails to connect to the host, it will wait for a while and will attempt to connect again. This function is used to set the waiting time. The factory default is 60 second.

6.8.6 Remote monitor

6.8.6.1 RMS EN/DISABLE

Accessing the RMS EN/DISABLE

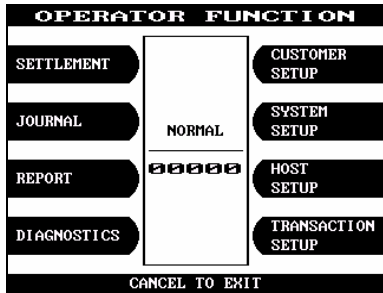

Select the 'HOST SETUP' in the OPERATOR FUNCTION menu.



Select the 'REMOTE MONITOR' in the HOST SETUP menu.

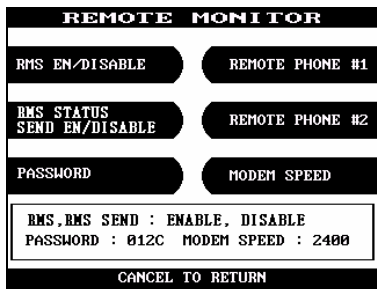

Select the 'RMS EN/DISABLE' in the REMOTE MONITOR menu.

Fig. 6.8.6.1 RMS EN/DISABLE

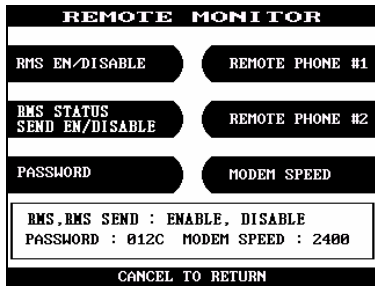

When you press the RMS EN/DISABLE key, it will be changed to to be enabled or disabled.

Fig. 6.8.6.1 RMS EN/DISABLE

Function Description

The RMS(Remote Management System) EN/DISABLE function is used to connect with the RMS mode in enabled or in disabled. The factory default is disabled.

6.8.6.2 RMS status send en/disable

Accessing the RMS STATUS SEND EN/DISABLE

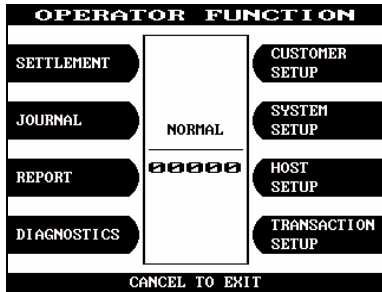

Select the 'HOST SETUP' in the OPERATOR FUNCTION menu.



Select the 'REMOTE MONITOR' in the HOST SETUP menu.

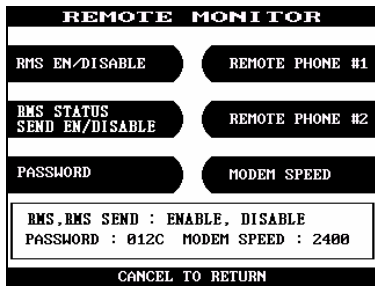

Select the 'RMS STATUS SEND EN/DISABLE' in the REMOTE MONITOR menu.

Fig. 6.8.6.2 RMS STATUS SEND EN/DISABLE

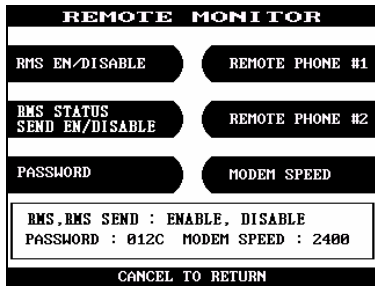

When you press the RMS STATUS SEND EN/DISABLE key, it will be changed to be enabled or disabled.

Fig. 6.8.6.2 RMS STATUS SEND EN/DISABLE

Function Description

The RMS(Remote Management System) STATUS SEND EN/DISABLE function is used to send Mini Bank 1500 status to the RMS when Mini Bank 1500 status is changed. The factory default is disabled.

6.8.6.3 Password

Accessing the PASSWORD

OPERATOR FUNCTION		
SETTLEMENT	NORMAL 000000	CUSTOMER SETUP
JOURNAL		SYSTEM SETUP
REPORT		HOST SETUP
DIAGNOSTICS		TRANSACTION SETUP
CANCEL TO EXIT		

Select the 'HOST SETUP' in the OPERATOR FUNCTION menu.

HOST SETUP	
KEY MANAGEMENT	CONNECT TIMER 60 SECOND
TELEPHONE NUMBER	REMOTE MONITOR
ID SETUP	COMM. KEY D/N
HEARTBEAT INTERVAL MESSAGE	CLOSE TIME
CANCEL TO RETURN	

Select the 'REMOTE MONITOR' in the HOST SETUP menu.

REMOTE MONITOR	
RMS EN/DISABLE	REMOTE PHONE #1
RMS STATUS SEND EN/DISABLE	REMOTE PHONE #2
PASSWORD	MODEM SPEED
RMS,RMS SEND : ENABLE, DISABLE PASSWORD : 012C MODEM SPEED : 2400	
CANCEL TO RETURN	

Select the 'PASSWORD' in the REMOTE MONITOR menu.

Fig. 6.8.6.3 PASSWORD

REMOTE MONITOR	
RMS EN/DISABLE	REMOTE PHONE #1
RMS STATUS SEND EN/DISABLE	REMOTE PHONE #2
PASSWORD	MODEM SPEED
ENTER MASTER PASSWORD [* * * * _]	
EDIT> ENTER TO CONFIRM	

Enter the MASTER Password.

REMOTE MONITOR	
RMS EN/DISABLE	REMOTE PHONE #1
RMS STATUS SEND EN/DISABLE	REMOTE PHONE #2
PASSWORD	MODEM SPEED
ENTER RMS PASSWORD [* * * * _]	
EDIT> ENTER TO CONFIRM	

Enter the new RMS Password.

REMOTE MONITOR	
RMS EN/DISABLE	REMOTE PHONE #1
RMS STATUS SEND EN/DISABLE	REMOTE PHONE #2
PASSWORD	MODEM SPEED
UERIFY RMS PASSWORD [* * * * _]	
EDIT> ENTER TO CONFIRM	

Enter the new RMS Password again.

REMOTE MONITOR	
RMS EN/DISABLE	REMOTE PHONE #1
RMS STATUS SEND EN/DISABLE	REMOTE PHONE #2
PASSWORD	MODEM SPEED
PASSWORD CHANGED	
CANCEL TO RETURN	

The password will be changed.

Fig. 6.8.6.3 PASSWORD

Function Description

The PASSWORD function is used to set the RMS password to connect to Mini Bank 1500 from RMS. The factory default RMS Password is “111111”.

6.8.6.4 Remote phone

Accessing the REMOTE PHONE

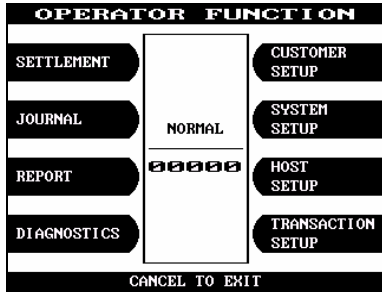

Select the 'HOST SETUP' in the OPERATOR FUNCTION menu.

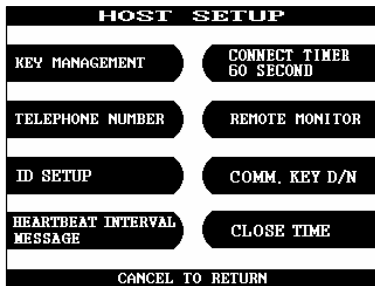

Select the 'REMOTE MONITOR' in the HOST SETUP menu.

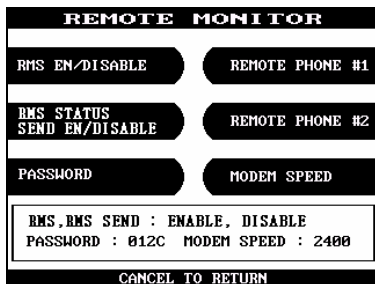

Select the 'REMOTE PHONE #1' in the REMOTE MONITOR menu.

Fig. 6.8.6.4 REMOTE PHONE

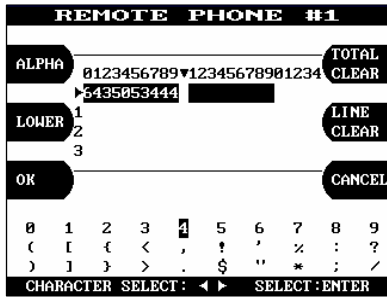

Enter the first Remote Phone number.
Please refer to 5.1.2 How to use keypad.

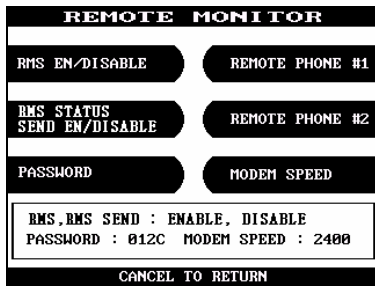

Select the 'REMOTE PHONE #2' in the REMOTE MONITOR menu.

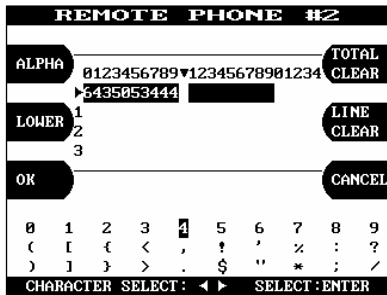

Enter the second Remote Phone number 2.
Please refer to 5.1.2 How to use keypad.

Fig. 6.8.6.4 REMOTE PHONE

Function Description

The REMOTE PHONE function is used to input the RMS Primary Telephone Number and the Back-up Telephone Number.

6.8.6.5 Modem speed

Accessing the MODEM SPEED

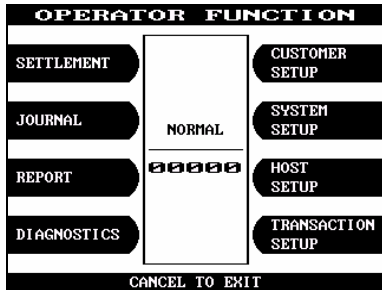

Select the 'HOST SETUP' in the OPERATOR FUNCTION menu.



Select the 'REMOTE MONITOR' in the HOST SETUP menu.

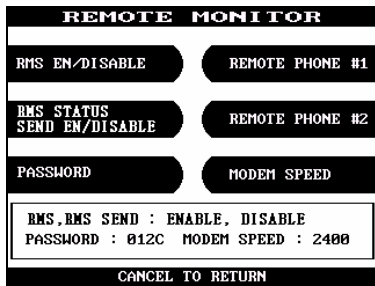

When you press the MODEM SPEED key, the speed will be changed to 300bps up to 56,600bps.

Fig. 6.8.6.5 MODEM SPEED

Function Description

The MODEM SPEED function is used to set the Modem speed of RMS and Mini Bank 1500.

6.8.7 Co mm. key D/N

Accessing the COMM. KEY D/N

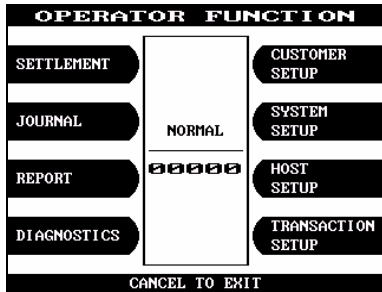

Select the 'HOST SETUP' in the OPERATOR FUNCTION menu.



Select the 'COMM. KEY D/N' in the HOST SETUP menu.



If you press 'COMM. KEY D/N' key, it will receive a working key from host.

Fig. 6.8.7 COMM. KEY D/N

Function Description

The COMM. KEY D/N function is used to set working key.

6.8.8 Close time

Accessing the CLOSE TIME

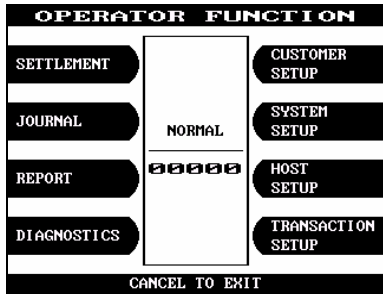

Select the 'HOST SETUP' in the OPERATOR FUNCTION menu.



Select the 'CLOSE TIME' in the HOST SETUP menu.

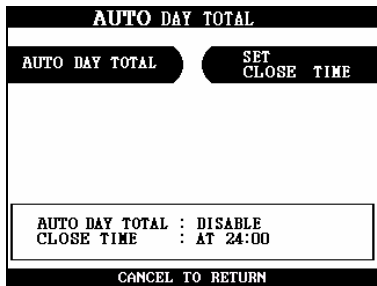

If you press 'AUTO DAY TOTAL' key, it will be changed to be enabled or disabled.

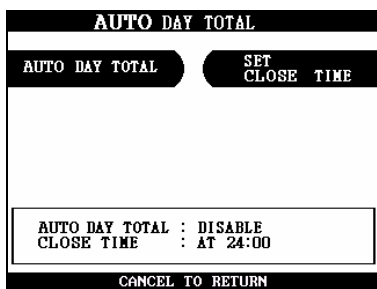

If you press 'SET CLOSE TIME' key, it will set close time.

Fig. 5.8.8 AUTO DAY TOTAL

Function Description

The AUTO DAY TOTAL function is used to run automatic action of DAY TOTAL.

6.9 Transaction Setup

The TRANSACTION SETUP function of the OPERATOR FUNCTION includes the following:

DISPENSE LIMIT
DENOMINATION
FAST CASH
CURRENCY LOW CHECK

6.9.1 Dispense limit

Accessing the DISPENSE LIMIT

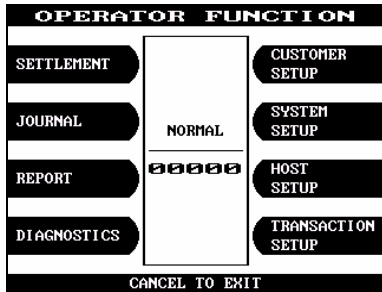

Select the 'TRANSACTION SETUP' in the OPERATOR FUNCTION menu.

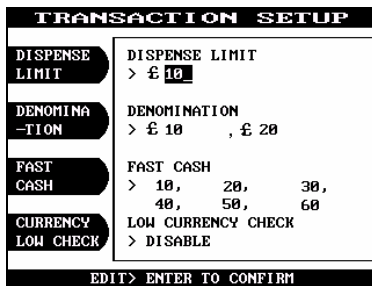

Enter the desired dispense limit after pressing the Dispense Limit screen key.

Fig. 6.9.1 DISPENSE LIMIT

Function Description

The DISPENSE LIMIT function is used to set the maximum amount of notes that can be dispensed per transaction. The maximum amount must be multiples of denomination. And the maximum number of notes must not be over totals of 40 notes. The factory default is £100.

6.9.2 Denomination

Accessing the DENOMINATION

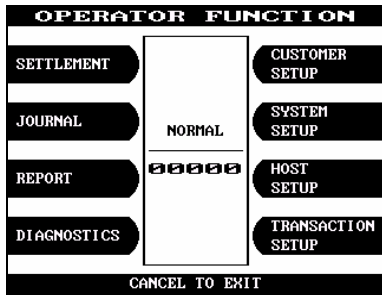

Select the 'TRANSACTION SETUP' in the OPERATOR FUNCTION menu.

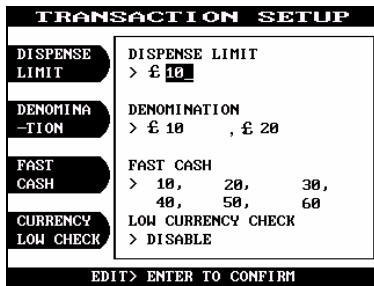

Select the 'DENOMINATION' in the TRANSACTION SETUP.

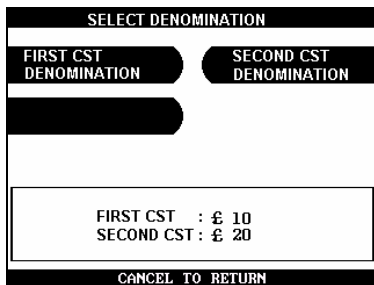

Enter the desired denomination of bills after pressing the Denomination key.

Fig. 6.9.2 DENOMINATION

Function Description

The DENOMINATION function is used to set the denomination of notes to be set in the cassette. The valid denomination is £10, £20, £50, £100. The factory default is £10 and £20.

6.9.3 Fast cash

Accessing the FAST CASH

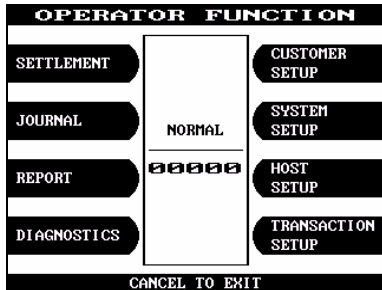

Select the 'TRANSACTION SETUP' in the OPERATOR FUNCTION menu.

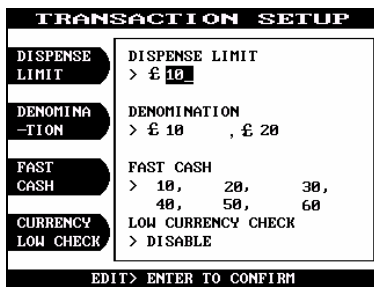

Select the 'FAST CASH' in the TRANSACTION SETUP menu.



You can change the fast cash amount LB0 to LB2 and RB0 to RB2 with press the button.

Fig. 6.9.3 FAST CASH

Function Description

The FAST CASH function is used to set the cash amount, which is to be displayed on the FAST CASH screen. The maximum amount must be less than the Dispensable Limit. The factory default is £10, £20, £30, £40, £50, £60.

6.9.4 Currency low check

Accessing the CURRENCY LOW CHECK

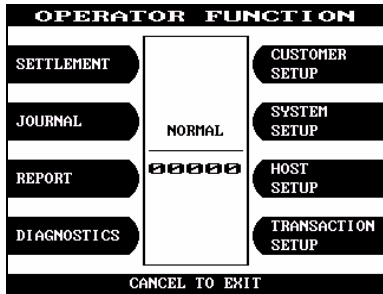

Select the 'TRANSACTION SETUP' in the OPERATOR FUNCTION menu.

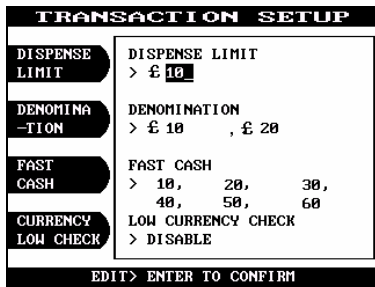

If you want to enable the Low Currency check function, press the Currency Low Check screen key once.

Fig. 6.9.4 CURRENCY LOW CHECK

Function Description

The CURRENCY LOW CHECK function is used to set the cassette low level detection. If this function is enabled, the machine will be changed to "OUT OF SERVICE" when notes are not enough in the cassette. The factory default is in disable.

7. Appendix

7. Appendix

A. RECEIPT PAPER SPECIFICATIONS

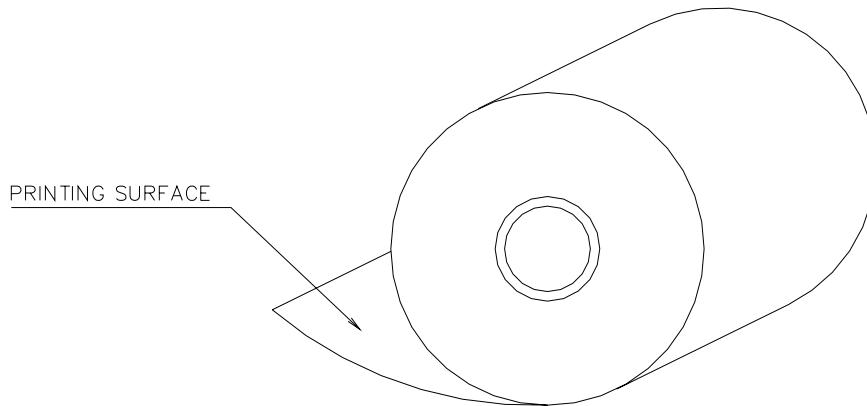
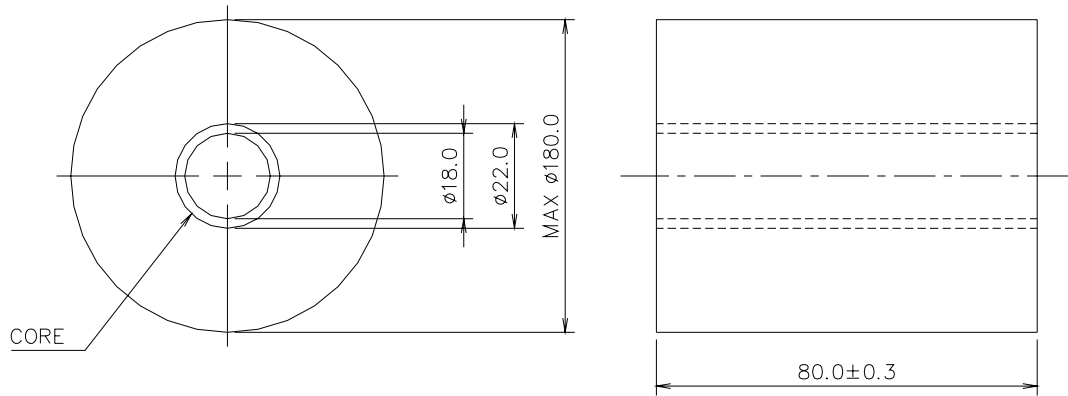

- All measurements are in mm.

B. Note Conditions

Acceptable Conditions

- Bill which is very clean and can readily be recognized as a true bill



- Bill have sufficient life or sizing to be handled easily



- Bill which can be manually held straightly when one end is held by a hand and the bill is slightly curved vertically

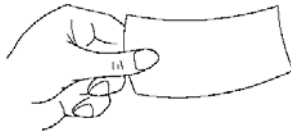

Unacceptable Conditions

- Bill having serious wrinkles, torn or broken section wherein paper fiber is broken and separation begins

- Wrinkle

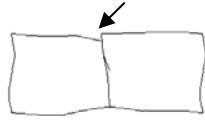

- Torn



- Broken section



- Bill having adequate life or sizing, but stained seriously



- Bill with holes (Perforated bill)



- Bill ragged and cannot be held straightly when one end is supported by a hand

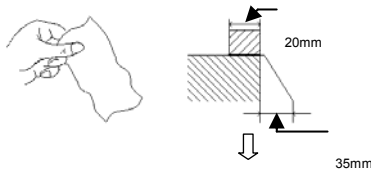

When the bill is held by 20mm and the straightness of the bill is 35mm or less, it cannot be used

- Bill with cellophane tape scotch tape, etc

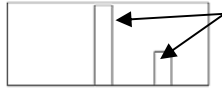

- Bill with folds



- Bill with folded lines

- Case 1



- Case 2



- Case 3



☞ Bill distortion should not exceed 10 mm

☞ "H" : Height

- Gradually curved bill (bills tied by hand seal, etc)

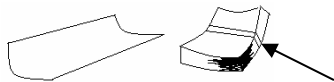

C. OPERATING & CHANGING THE ELECTRONIC COMBINATION LOCK

USER CODE

- Open Lock
- Change Code

WRONG TRY PENALTY

- Four (4) consecutive invalid codes initiates five minute delay period.

LOW BATTERY WARNING

- Repeated audio and visual signal (LED flashing and repeated beeping) during opening indicates battery low.



AUDIO AND VISUAL SIGNAL

- Double signal (LED flashes and unit beeps) indicates entry is valid or accepted.
- Triple signal indicates invalid or not accepted.

OPENING THE LOCK

1. Enter valid six (6) digit code.
 2. The lock will signal a valid code entry with a double signal.
 3. Within four (4) seconds, turn handle to the open position.
 4. Pull door open.
- Invalid Code Entry - Lock will signal three (3) times.

WRONG TRY PENALTY

- Entry of four (4) consecutive invalid codes starts a 5-minute delay period.
 - LED flashed red at five (5) second intervals.
- At the end of the delay period, two more consecutive invalid codes will restart an additional 5-minute delay period.

CHANGING YOUR CODE

ALWAYS PERFORM THIS OPERATION WITH THE DOOR OPEN

1. Enter "zero" six times.
 2. Enter your existing six (6) digit code one time.
 3. Enter your NEW six (6) digit code two times.
 4. If a mistake is made wait thirty (30) seconds and repeat steps 1. - 3.
 5. Test lock operation several times before closing the door.
- Valid Code Entry - Double signal after valid six (6) digit code is entered.
 - Invalid Code Entry - Triple signal and old code is still valid.

BATTERY LOW WARNING

- Repeated beeping during an opening indicates that the battery is low and needs immediate replacement.
- Uses one (1) 9-Volt Alkaline Battery. LA GARD recommends the use of Duracell™ or Everready™ Alkaline batteries.

If battery is depleted and will not allow lock to open, simply follow instructions below.

CHANGING YOUR BATTERY

Note: Some manufacturers use a small screw to secure the battery compartment cover to the keypad housing. If your model has this screw, it must be removed first before following the steps listed below.

1. Remove black plastic battery compartment cover (located at the bottom of the keypad) by gently pulling downward on it's handle.
2. Allow the battery and it's attached leads to drop down and out of the battery compartment. If it does not drop, gently pull on the battery until it does.
3. The connector is easily removed by unsnapping it from the two terminals on the top of the battery. Never Pull on the Battery Leads
4. Connect a new 9-Volt Alkaline battery to the battery clip.
5. Push the battery and the leads completely up into the battery compartment.
6. Install the battery cover by placing one side of the cover in position and then pressing the other side into position with your finger.

D. ERROR CODES

ERROR CODES	ERROR DESCRIPTION	CORRECTIVE ACTION
00000	Normal Status	Normal Status
20001	Cash cassette is not properly set.	Set the cash cassette properly.
20002	Cash cassette empty.	Load the cash into the cash cassette and set the number of bills.
20003	Reject Bin full.	Empty the Reject Bin.
20004	Security Door open.	Close the Security Door.
20010	Receipt paper jam.	Clear the jammed paper.
20012	Receipt Printer feed lever open.	Close the feed lever.
20013	Receipt paper empty.	Load the receipt paper.
20014	Receipt Printer thermal head over heated.	Call your service personnel.
20015	Note detected.	Clear jammed notes or call your service personnel.
Axxx1	Receipt Printer feed lever open.	Close the feed lever.
Axxx2	Receipt Printer thermal head over heated.	Call your service personnel.
Axxx3	Receipt paper jam.	Clear the jammed paper.
Axxx4	Receipt paper empty.	Load the receipt paper.
Axxx5	Receipt paper setting error.	Clear the paper and reload.
Axxx6	Receipt Printer DIP switch error.	Call your service personnel.
Axxx7	Receipt Printer Lever Opened	Check sensor, cable connection and connector
Axxx8	Receipt Printer cutter error.	Check paper jam, or call your service personnel.
ADNxx	Receipt Printer connection failure.	If error is not recovered, call your service personnel.
C0001 ~ C002F	CDU sensor blocked.	Clear the note path or call your service personnel.
C0030	CDU main motor failure.	Call your service personnel.
C0031	CDU gate solenoid echo error.	Call your service personnel.
C0032	CDU outlet solenoid echo error.	Call your service personnel.
C0033	CDU encoder error.	Call your service personnel.
C0034	CDU double detect module failure 1	Call your service personnel.
C0035	CDU double detect module failure 2	Call your service personnel.
C0036	Note detected (outlet sensor)	Clear the note from the outlet sensor.
C0037	CDU double detect module failure 3	Call your service personnel.

ERROR CODES	ERROR DESCRIPTION	CORRECTIVE ACTION
C0040	Cash cassette taken out during dispense	Set the cash cassette properly
C0041	Dispensing error	Call your service personnel
C0042	Note jam	Clear jammed notes or call your service personnel.
C0043	Over 10 notes has been rejected per 1 transaction.	Check notes or call your service personnel.
C0044	Over 5 notes has been rejected continuously.	Check notes or call your service personnel.
C0045	Too many notes dispensed continuously.	Check notes and note set status.
C0046	CDU hardware failure	Call your service personnel.
C0047	1st Cassette Misfeed	Check notes and note set status.
C0048	Wrong count.	Check notes and note set status or Call your service personnel.
C004A	Note jam.	Call your service personnel.
C004B	Many notes too close.	Call your service personnel.
C004C	Wrong count	Check notes or note set status or call your service personnel
C004D	Cash cassette is not properly set	Set the cash cassette properly
C004E	Wrong count	Call your service personnel
C004F	Wrong count(over dispensed)	Call your service personnel
C0050	Power failed during dispensing	Check journal for last transaction
C0051	Too many notes requested	Call your service personnel
C0052	Note detected(CS1A, CS1B)	Clear jammed notes or
C0053	CDU double detect module failure 4	Call your service personnel
C0055	Long note detected(outlet sensor)	Call your service personnel
C005B	2nd Cassette Misfeed	Check notes and note set status.
C009F	3rd Cassette Misfeed	Check notes and note set status.
CDNxx	CDU connection failure.	If error is not recovered, call your service personnel.
Dxx01	Modem reset failure	Call your service personnel.
Dxx02	Reversal failure	Call your service personnel
D0011 ~ D0099	Transaction Error responded by Host	Check transaction history in Host and try again
D009A ~	Communication Error	Check phone line status Check modem

ERROR CODES	ERROR DESCRIPTION	CORRECTIVE ACTION
E0001	RMS port failure	Call your service personnel.
E0002	RMS response timeout	Call your service personnel.
E0003	RMS modem failure	Call your service personnel.
E0004	RMS no dial tone	Call your service personnel.
E0005	RMS retry over	Call your service personnel.
F0001	Number of Bill is not inputted	Input number of Bill
F0002	Surcharge Owner is not inputted in Surcharge Enable	Input Surcharge Owner
F0003	Surcharge Amount is not inputted in Surcharge Enable	Input Surcharge Amount
F0004	Refresh timer is not inputted in Advertisement Enable	Input Refresh timer
F0005	Advertisement text is not inputted in Advertisement Enable	Input Advertisement text
F0006	Error in Dispense Limit setting	Check Dispense Limit and reset
F0007	Error in inputting Note Currency	Check note currency and reset
F0008	Error in Fast Cash setting	Check Fast Cash Value and reset
F0009	Master Key Index invalid (0 <= MKEY Index <= 15)	Check Master Key and reset
F000A	Master Key Empty	Input Master Key
F000B	Host Phone Number is not inputted	Input Host Phone Number
F000C	Error Retry Timer is not inputted	Input Error Retry Timer
F000D	RMS Password is not inputted in RMS Enable	Input RMS Password
F000E	RMS Phone Number is not inputted in RMS Enable	Input RMS Phone Number
F000F	Terminal Number is not inputted	Input Terminal Number
F0010	Routing ID is not inputted	Input Routing ID
F0011	Master Key Serial Number is not inputted	Input Master Key Serial Number
F0012	Non-Cash Type text is not in/out (only MB-2100, 2200)	Input Non-Cash Type
F0013	Parameter is not properly set	Input Non-Cash Value
F0014	NVRAM Failure	Check Battery and Battery Plug Change Main Board

E. HOW TO CLEAR NV-RAM

Accessing the NV-RAM CLEAR

Turn on Mini Bank 1500 while pressing F6 key(upper-right 2nd key)
After initializing, follow below pictures...



Select 'YES' in the CLEAR NVRAM MENU.



Select 'YES' in the APPLY EPP MENU.



Enter the NVRAM CLEAR PASSWORD.
If the wrong password is entered, the screen will be back to "ENTER PASSWORD" screen.
The factory default NV-RAM Clear Password is "000321".

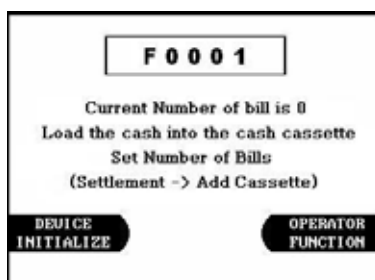

Select 'OPERATION FUNCTION' in the ERROR CODE of REPORT MENU.



Enter the OPERATOR PASSWORD.
 If the wrong password is entered, the screen will be back to “ENTER PASSWORD” screen.
 The factory default Master Password is “375876”

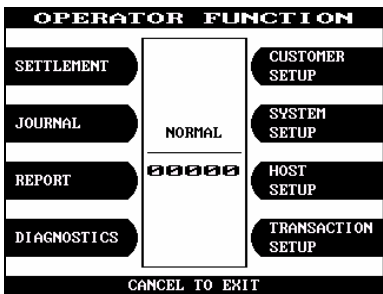

If the correct password is entered, the OPERATOR FUNCTION MENU will be displayed

F. PICTURES OF MINI BANK 1500

This page is for pictures of Mini Bank 1500.

FRONT VIEW OF MINI BANK 1500 (FULL)
REAR VIEW OF MINI BANK 1500 (FULL)
FRONT VIEW OF MINI BANK 1500 (UPPER ONLY)
FRONT AND REAR VIEW OF CONTROL ELECTRONICS BOARD
FRONT AND REAR VIEW OF CARD READER
FRONT VIEW OF VISA EPP
LABEL OF MINI BANK 1500

F.1 FRONT VIEW OF MINI BANK 1500 (FULL)



F.2 REAR VIEW OF MINI BANK 1500 (FULL)



F.3 FRONT VIEW OF MINI BANK 1500 (UPPER ONLY)



F.4 FRONT AND REAR VIEW OF CONTROL ELECTRONICS BOARD



F.5 FRONT AND REAR VIEW OF IFM



F.6 FRONT VIEW OF VISA EPP



F.7 LABEL OF MINI BANK 1500



Remark

‘Mini Bank 1500’ is Brand Name and ‘HS-1430’ is Model Name.
Don’t be confused.